

12. TRANSMISSION/GEARSHIFT LINKAGE

COMPONENT LOCATION	12-2	GEARSHIFT SPINDLE	12-7
SERVICE INFORMATION	12-4	TRANSMISSION.....	12-11
TROUBLESHOOTING	12-6		

TRANSMISSION/GEARSHIFT LINKAGE

COMPONENT LOCATION

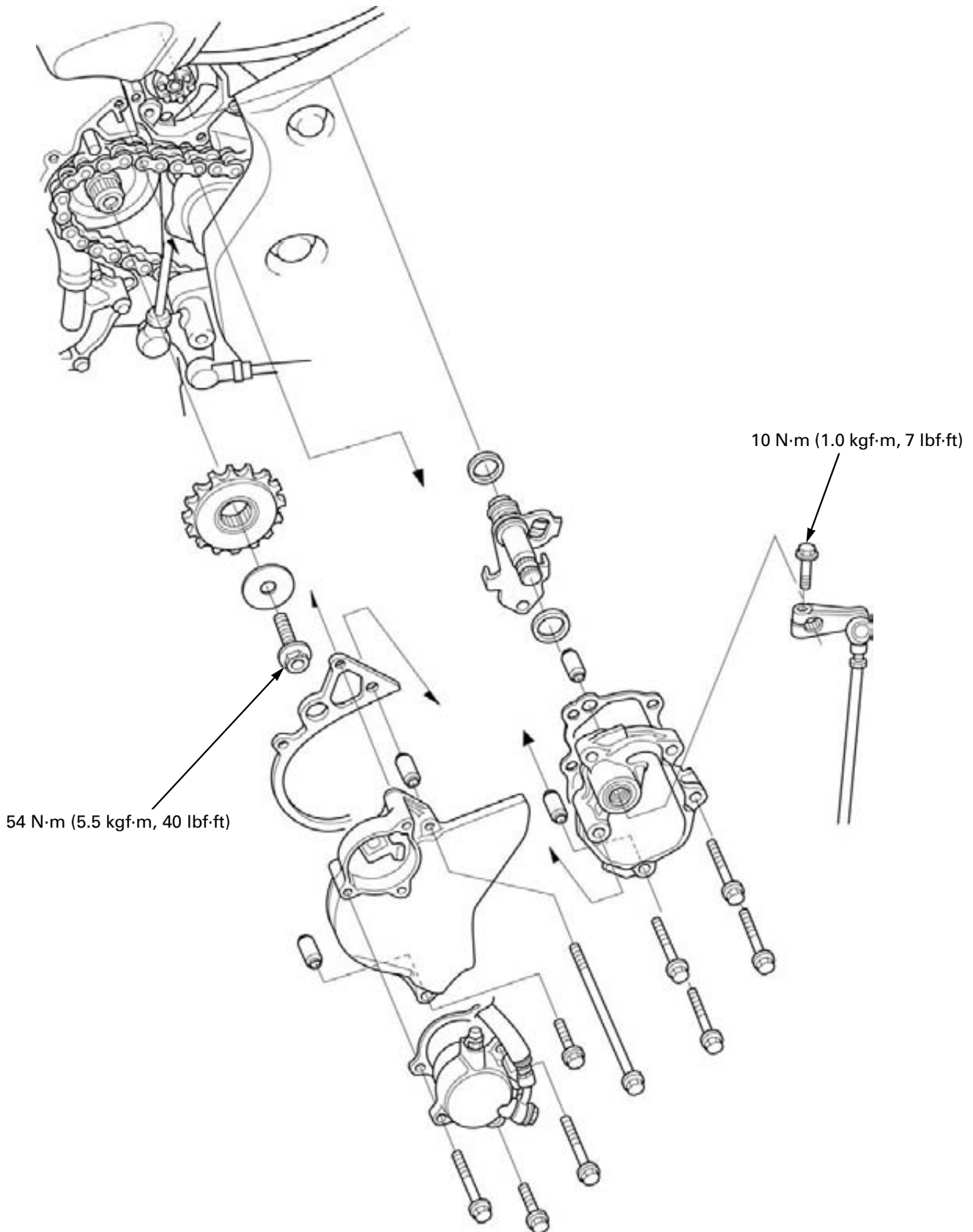

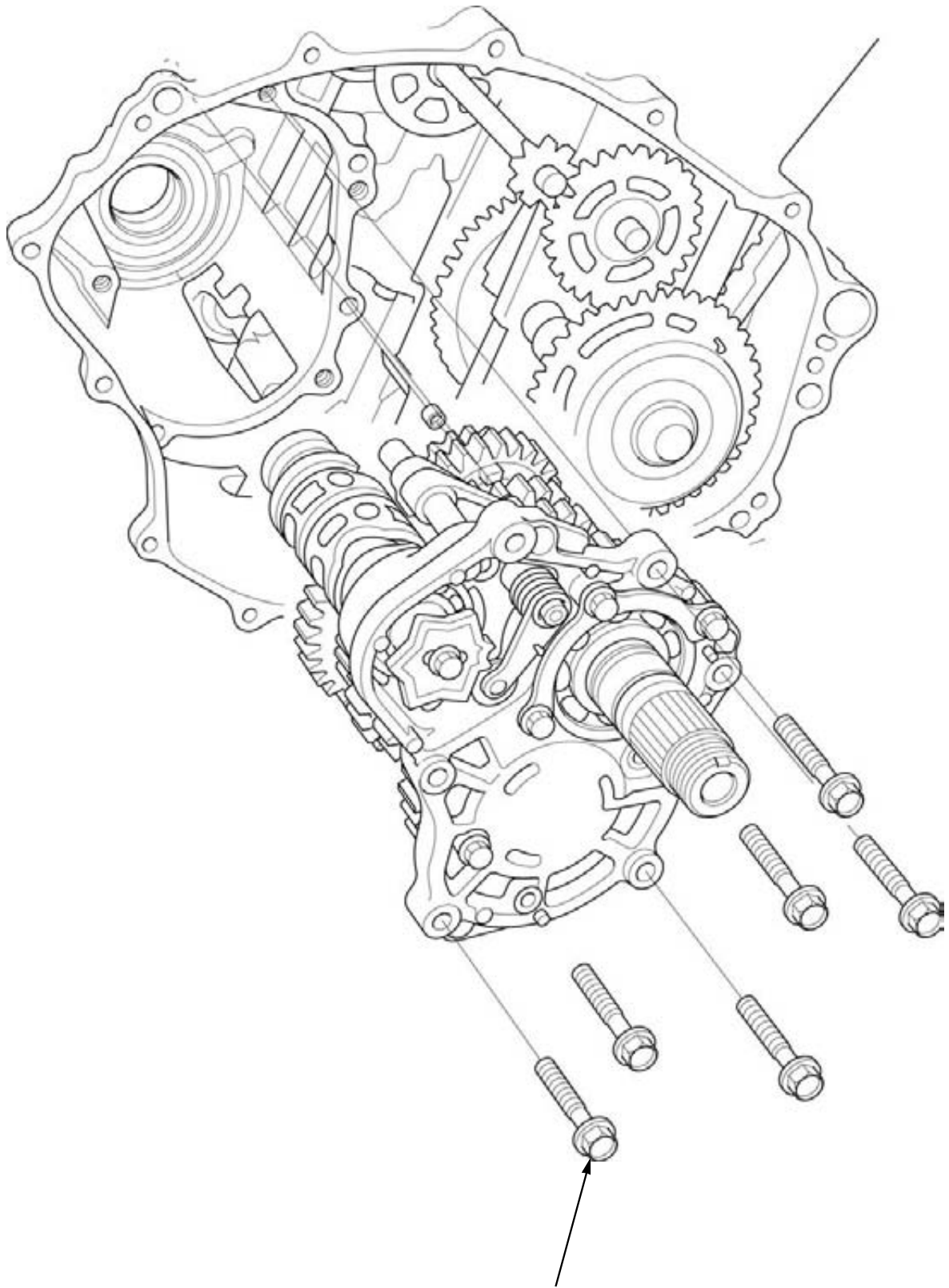

29 N·m (3.0 kgf·m, 21 lbf·ft)

TRANSMISSION/GEARSHIFT LINKAGE

SERVICE INFORMATION

GENERAL

- This section covers the transmission and gearshift linkage service. These service can be done engine installed in the frame.

SPECIFICATIONS









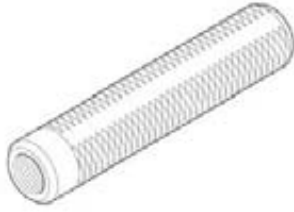

Unit: mm (in)

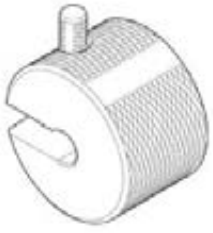
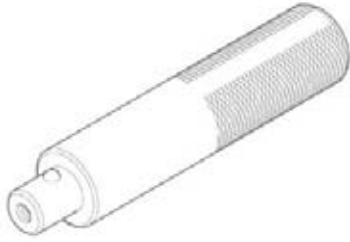
ITEM			STANDARD	SERVICE LIMIT
Shift fork	I.D.		12.000 – 12.018 (0.4724 – 0.4731)	12.03 (0.474)
	Claw thickness		5.93 – 6.00 (0.233 – 0.236)	5.9 (0.23)
Shift fork shaft O.D.			11.957 – 11.968 (0.4707 – 0.4712)	11.95 (0.470)
Transmission	Gear I.D.	M5, M6	31.000 – 31.025 (1.2205 – 1.2215)	31.04 (1.222)
		C1	28.000 – 28.021 (1.1024 – 1.1032)	28.04 (1.104)
		C2, C3, C4	33.000 – 33.025 (1.2992 – 1.3002)	33.04 (1.301)
	Gear busing O.D.	M5, M6	30.955 – 30.980 (1.2187 – 1.2197)	30.935 (1.2179)
		C2	32.955 – 32.980 (1.2974 – 1.2984)	32.935 (1.2967)
		C3, C4	32.950 – 32.975 (1.2972 – 1.2982)	32.930 (1.2964)
	Gear-to-bushing clearance	M5, M6	0.020 – 0.070 (0.0008 – 0.0028)	0.10 (0.004)
		C2	0.020 – 0.070 (0.0008 – 0.0028)	0.10 (0.004)
		C3, C4	0.025 – 0.075 (0.0010 – 0.0030)	0.11 (0.004)
	Gear bushing I.D.	M5	27.985 – 28.006 (1.1018 – 1.1026)	28.016 (1.1030)
		C2	29.985 – 30.006 (1.1018 – 1.1026)	30.021 (1.1819)
	Mainshaft O.D.	at M5	27.967 – 27.980 (1.1011 – 1.1016)	27.957 (1.1007)
	Countershaft O.D.	at C2	29.967 – 29.980 (1.1798 – 1.1803)	29.960 (1.1795)
	Bushing to shaft clearance	M5	0.005 – 0.039 (0.0002 – 0.0015)	0.06 (0.002)
C2		0.005 – 0.039 (0.0002 – 0.0015)	0.06 (0.002)	

TORQUE VALUES

Transmission holder flange bolt	29 N·m (3.0 kgf·m, 21 lbf·ft)	Apply a locking agent to the threads.
Countershaft bearing set plate bolt	12 N·m (1.2 kgf·m, 9 lbf·ft)	
Mainshaft bearing set plate bolt	12 N·m (1.2 kgf·m, 9 lbf·ft)	Apply a locking agent to the threads.
Shift drum center socket bolt	23 N·m (2.3 kgf·m, 17 lbf·ft)	(Apply a locking agent to the threads)
Shift drum stopper arm pivot bolt	12 N·m (1.2 kgf·m, 9 lbf·ft)	Apply a locking agent to the threads.
Gearshift spindle return spring pin	23 N·m (2.3 kgf·m, 17 lbf·ft)	
Shift drum bearing setting bolt	12 N·m (1.2 kgf·m, 9 lbf·ft)	
Gearshift cam bolt	12 N·m (1.2 kgf·m, 9 lbf·ft)	Apply a locking agent to the threads.
Gearshift arm pinch bolt	10 N·m (1.0 kgf·m, 7 lbf·ft)	

TOOLS

<p>Bearing remover handle 07936-3710100</p> 	<p>Bearing remover set, 20 mm 07936-3710600</p> 	<p>Remover weight 07741-0010201</p> 
<p>Driver 07749-0010000</p> 	<p>Attachment, 42 x 47 mm 07746-0010300</p> 	<p>Attachment, 52 x 55 mm 07746-0010400</p> 
<p>Attachment, 62 x 68 mm 07746-0010500</p> 	<p>Attachment, 42 x 47 mm 07746-0010300</p> 	<p>Pilot, 20 mm 07746-0040500</p> 
<p>Pilot, 25 mm 07746-0040600</p> 	<p>Pilot, 28 mm 07746-0041100</p> 	

TROUBLESHOOTING

Hard to shift

- Improper clutch operation
- Incorrect engine oil weight
- Bent shift fork
- Bent shift fork shaft
- Bent shift fork claw
- Damaged shift drum cam groove
- Bent gearshift spindle

Transmission jumps out of gear

- Worn gear dogs
- Worn gear shifter groove
- Bent shift fork shaft
- Broken shift drum stopper arm
- Broken shift drum stopper arm spring
- Worn or bent shift forks
- Broken gearshift spindle return spring

Excessive engine noise

- Worn or damaged transmission gear
- Worn or damaged transmission bearings

GEARSHIFT SPINDLE

REMOVAL

Remove the pinch bolt and remove the gear shift arm from the gear shift spindle.

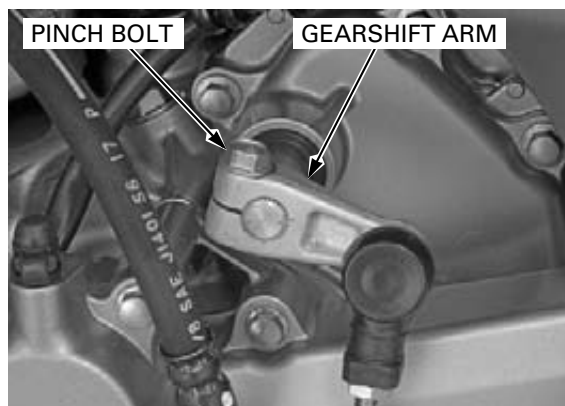

Remove the clutch slave cylinder (page 10-13).

Remove the clutch lifter rod.

Remove the bolts and left crankcase rear cover.

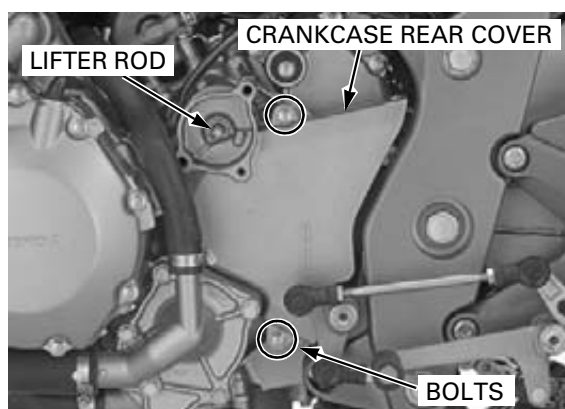

Remove the guide plate and dowel pins.

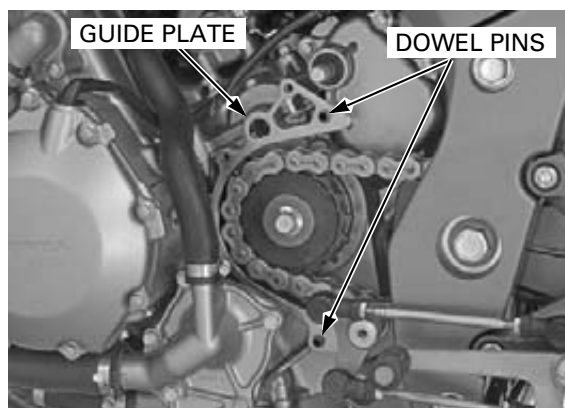

Loosen the rear axle nut and turn the drive chain adjusting bolts to make the drive chain slack fully (page 4-21).

Remove the drive sprocket bolt, washer and drive sprocket.

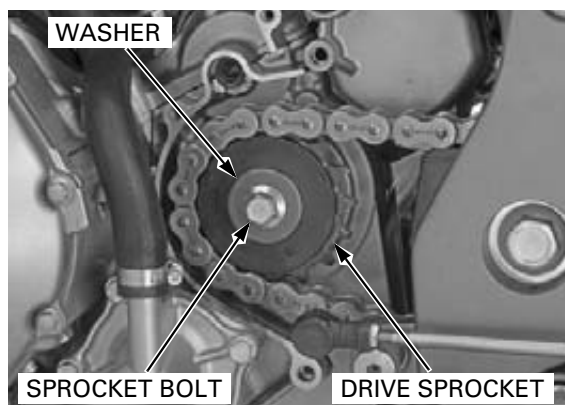

TRANSMISSION/GEARSHIFT LINKAGE

Remove the air cleaner duct (page 4-7).
Remove the wire band from the linkage cover.
Remove the bolts and gearshift linkage cover.

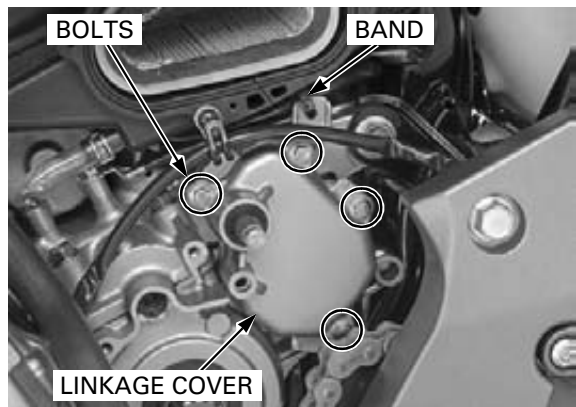

Remove the gasket and dowel pins.

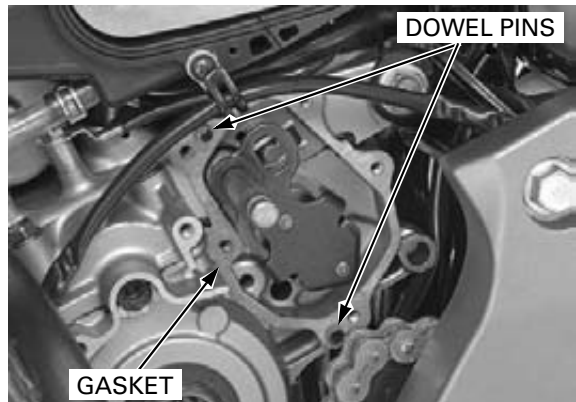

Remove the gearshift spindle and washers.

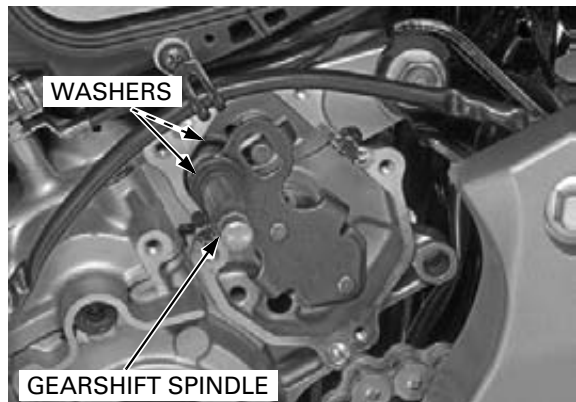

INSPECTION

Check the gearshift spindle for wear, damage or bending.
Check the return spring for fatigue or damage.
If the snap rings are removed, install them with their chamfered side facing the return spring.

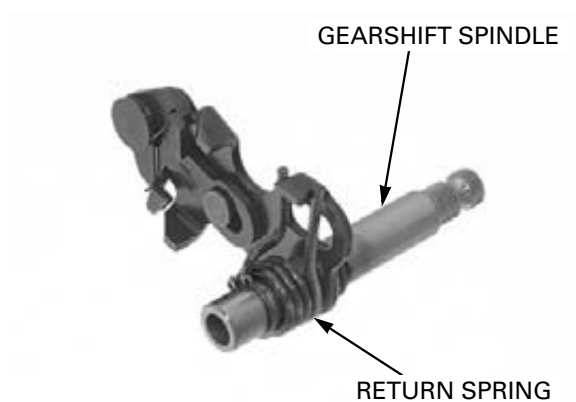

Check the dust seal for damage or deterioration.
Check the needle bearing for wear or damage.

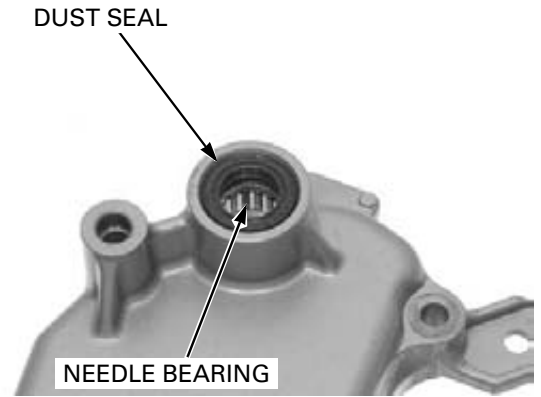

INSTALLATION

Install the washers to the gearshift spindle.

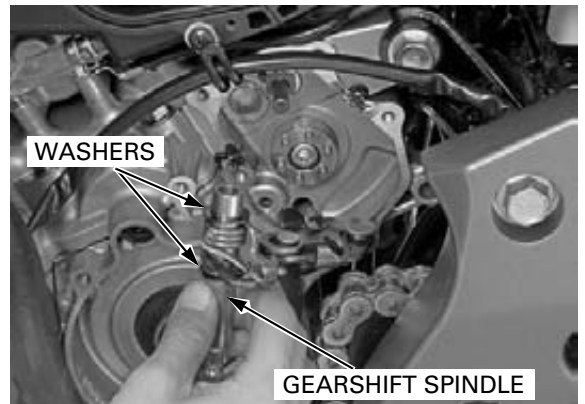

Install the gearshift spindle into the crankcase with the washers.

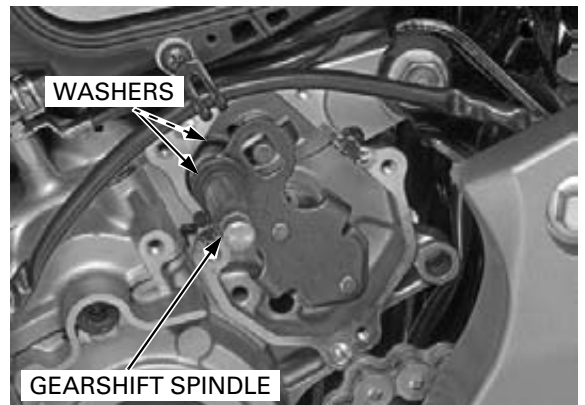

Install a dowel pins and new gasket.

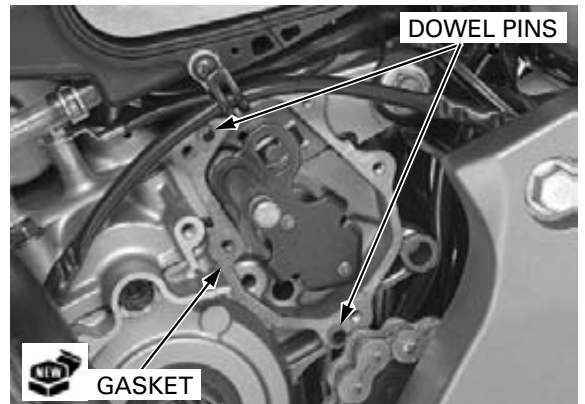

TRANSMISSION/GEARSHIFT LINKAGE

Install the gearshift linkage cover being careful not to damage the oil seal lips.

Apply a locking agent to the threads of the bolt indicated.

Install and tighten the linkage cover bolts.

Secure the starter motor cable and ground cable with the wire band through the linkage cover hole.

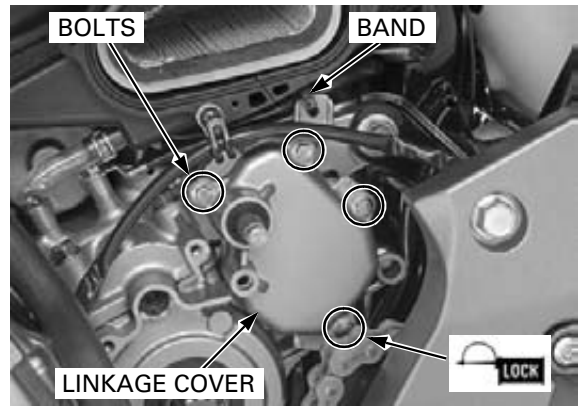

Install the drive sprocket with its "ML7" mark facing out.

Install the washer and drive sprocket bolt, then tighten the drive sprocket bolt to the specified torque.

TORQUE: 54 N·m (5.5 kgf·m, 40 lbf·ft)

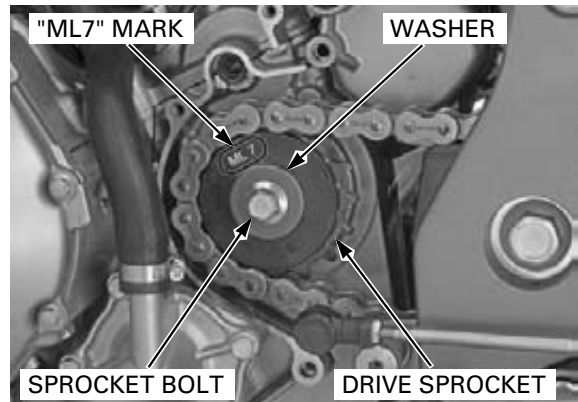

Install the dowel pins and guide plate.

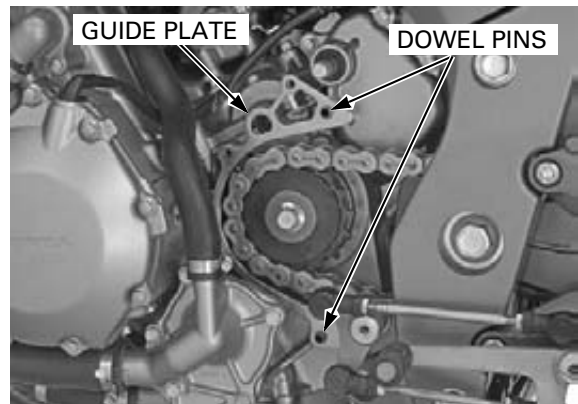

Install the left crankcase rear cover and tighten the mounting bolts.

Install the clutch lifter rod.

Install the clutch slave cylinder (page 10-13).

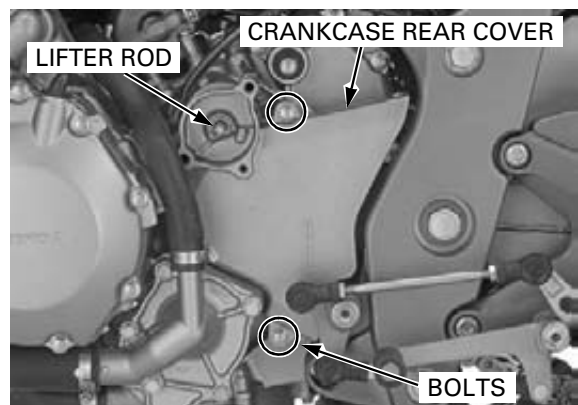

Align the punch mark on the gearshift arm with the rear punch mark on the spindle.

Install the gearshift arm onto the gearshift spindle, then tighten the pinch bolt.

TORQUE: 10 N·m (1.0 kgf·m, 7 lbf·ft)

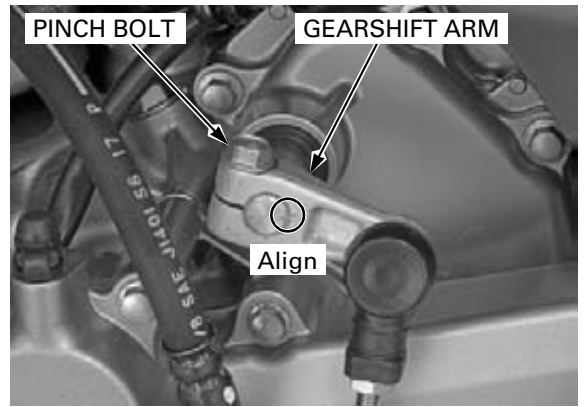

Check the pivot dust seals for deterioration or damage, replace them if necessary.

If the gearshift pedal has been removed, install the washer, gearshift pedal and pivot bolt onto the frame.

Tighten the pivot bolt to the specified torque.

TORQUE: 26 N·m (2.7 kgf·m, 20 lbf·ft)

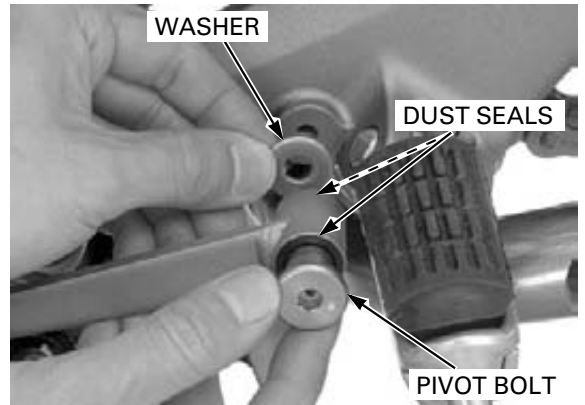

TRANSMISSION

REMOVAL

Remove the following:

- Right crankcase cover (page 10-15)
- Clutch (page 10-17)
- Drive sprocket (page 12-7)

Remove the transmission holder mounting bolts.

Pull out the transmission holder and transmission assembly from the crankcase.

Be careful not to fall the oil orifice into the crankcase when removing the transmission holder.

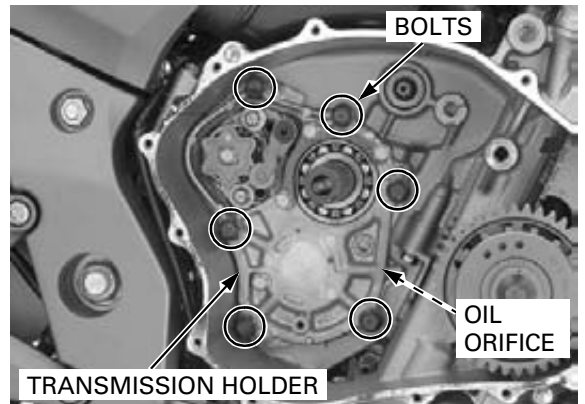

Remove the oil orifice from the crankcase.



TRANSMISSION/GEARSHIFT LINKAGE

DISASSEMBLY

Remove the shift fork shafts and shift forks.

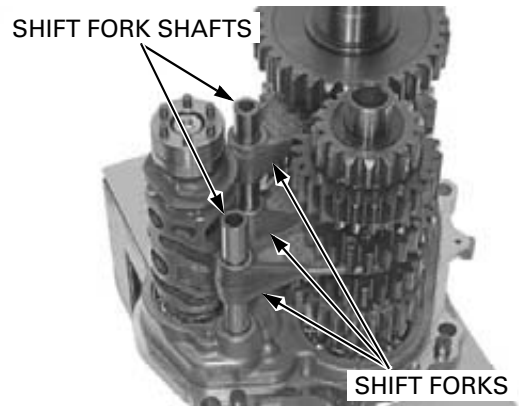

Remove the mainshaft and countershaft assembly.

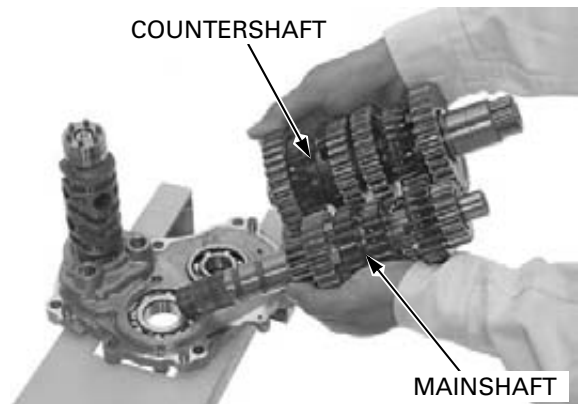

Remove the pivot bolt, washer, stopper arm and return spring.

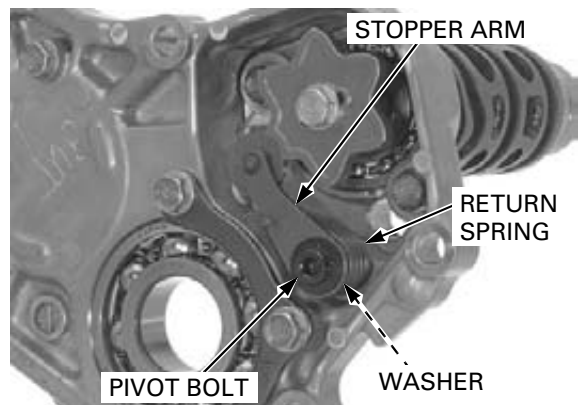

Remove the bolt and gearshift cam.

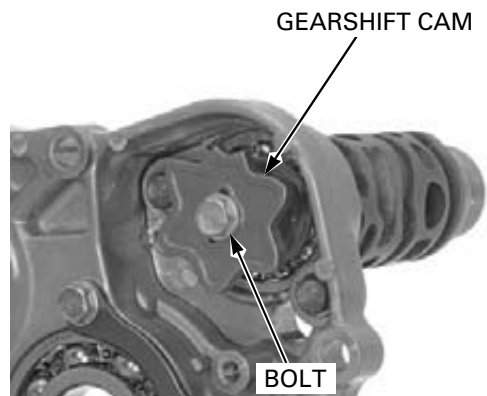

Remove the dowel pins from the shift drum.
Remove the flange collar.

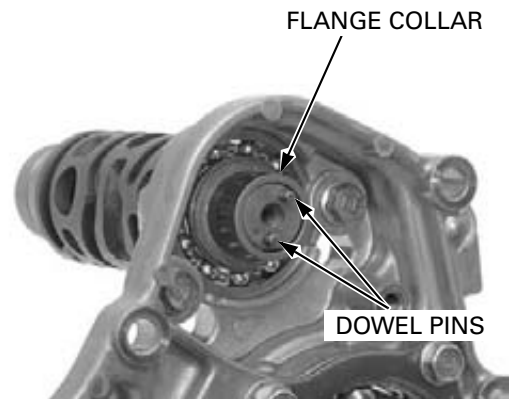

Remove the shift drum from the transmission holder.

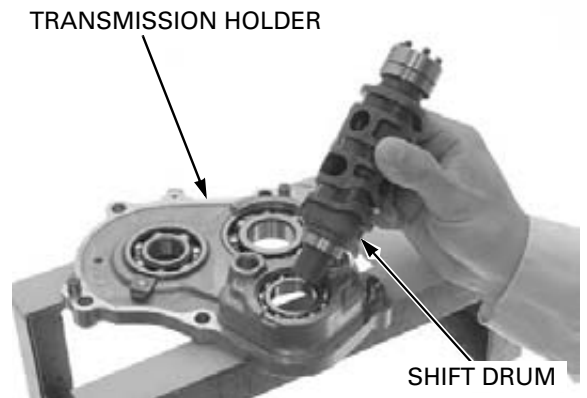

Disassemble the mainshaft and countershaft assembly.

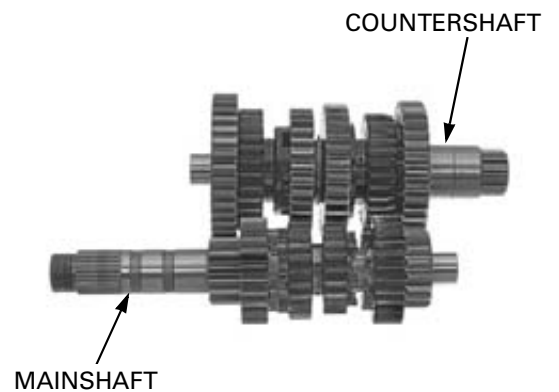

INSPECTION

Check the shift fork guide pin for abnormal wear or damage

Measure the shift fork I.D.

SERVICE LIMIT: 12.03 mm (0.474 in)

Measure the shift fork claw thickness.

SERVICE LIMIT: 5.9 mm (0.23 in)



TRANSMISSION/GEARSHIFT LINKAGE

Measure the shift fork shaft O.D.

SERVICE LIMITS: 11.95 mm (0.470 in)

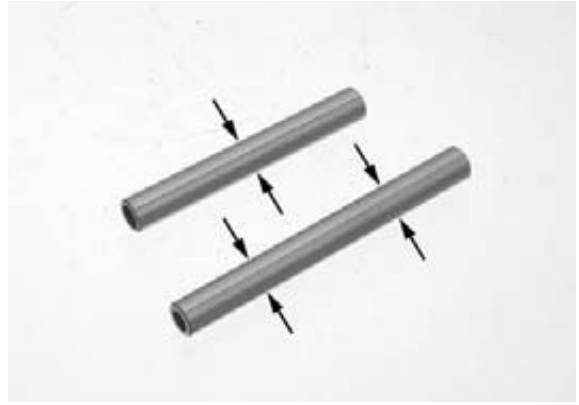

Turn the outer race of the shift drum bearing with your finger.
The bearing should turn smoothly and freely without excessive play.
If necessary replace the bearing.



Inspect the shift drum guide grooves for abnormal wear or damage.

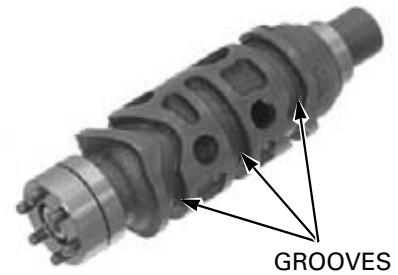

Check the gear dogs, dog holes and teeth for abnormal wear or lack of lubrication.

Measure the I.D. of each gear.

SERVICE LIMITS:

M5, M6: 31.04 mm (1.222 in)

C1: 28.04 mm (1.104 in)

C2, C3, C4: 33.04 mm (1.301 in)



Measure the O.D. of each gear bushing.

SERVICE LIMITS:

M5, M6: 30.935 mm (1.2179 in)

C2: 32.935 mm (1.2967 in)

C3, C4: 32.930 mm (1.2964 in)

Measure the I.D. of each gear bushing.

SERVICE LIMITS:

M5: 28.016 mm (1.1030 in)

C2: 29.960 mm (1.1795 in)

Calculate the gear-to-bushing clearance.

SERVICE LIMITS:

M5, M6: 0.10 mm (0.004 in)

C2: 0.10 mm (0.004 in)

C3, C4: 0.11 mm (0.004 in)

Check the gear shifter groove for abnormal wear or damage.



SHIFTER GROOVE



Check the mainshaft and countershaft for abnormal wear or damage.

Measure the mainshaft O.D. at the M5 gear.

SERVICE LIMIT: 27.957 mm (1.1007 in)

Measure the countershaft O.D. at the C2 gear.

SERVICE LIMIT: 29.960 mm (1.1795 in)

Calculate the gear bushing-to-shaft clearance.

SERVICE LIMITS:

M5: 0.06 mm (0.002 in)

C2: 0.06 mm (0.002 in)

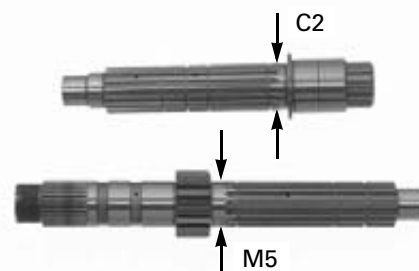

Turn the inner race of each transmission bearings with your finger.

The bearing should turn smoothly and freely without excessive play.

If necessary replace the bearing (page 12-16).



TRANSMISSION/GEARSHIFT LINKAGE

TRANSMISSION BEARING REPLACEMENT

Replace the transmission holder and crankcase as a set.

Remove the bolts and shift drum bearing setting bolts.

Remove the bolts and mainshaft bearing set plate.

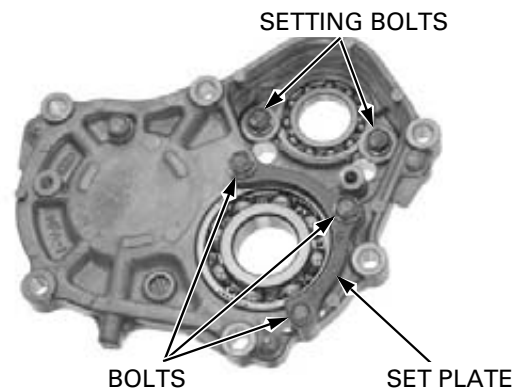

Remove the bolt and countershaft bearing set plate.

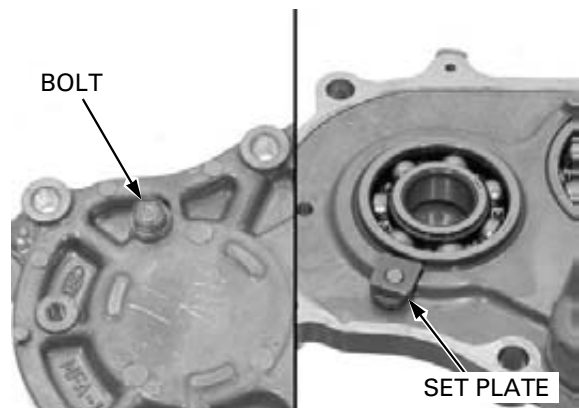

Remove the countershaft bearing using the special tools.

TOOLS:

Bearing remover handle	07936-3710100
Bearing remover set	07936-3710600
Remover weight	07741-0010201

Drive out the countershaft bearing and shift drum bearing.

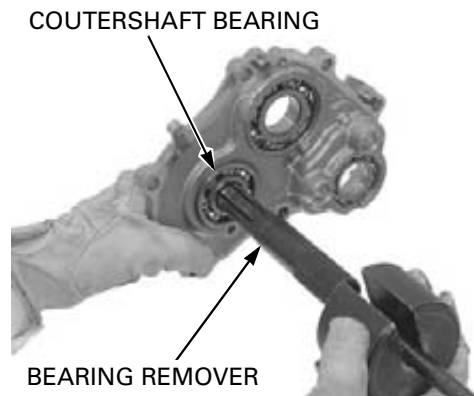

Bearing Locations:

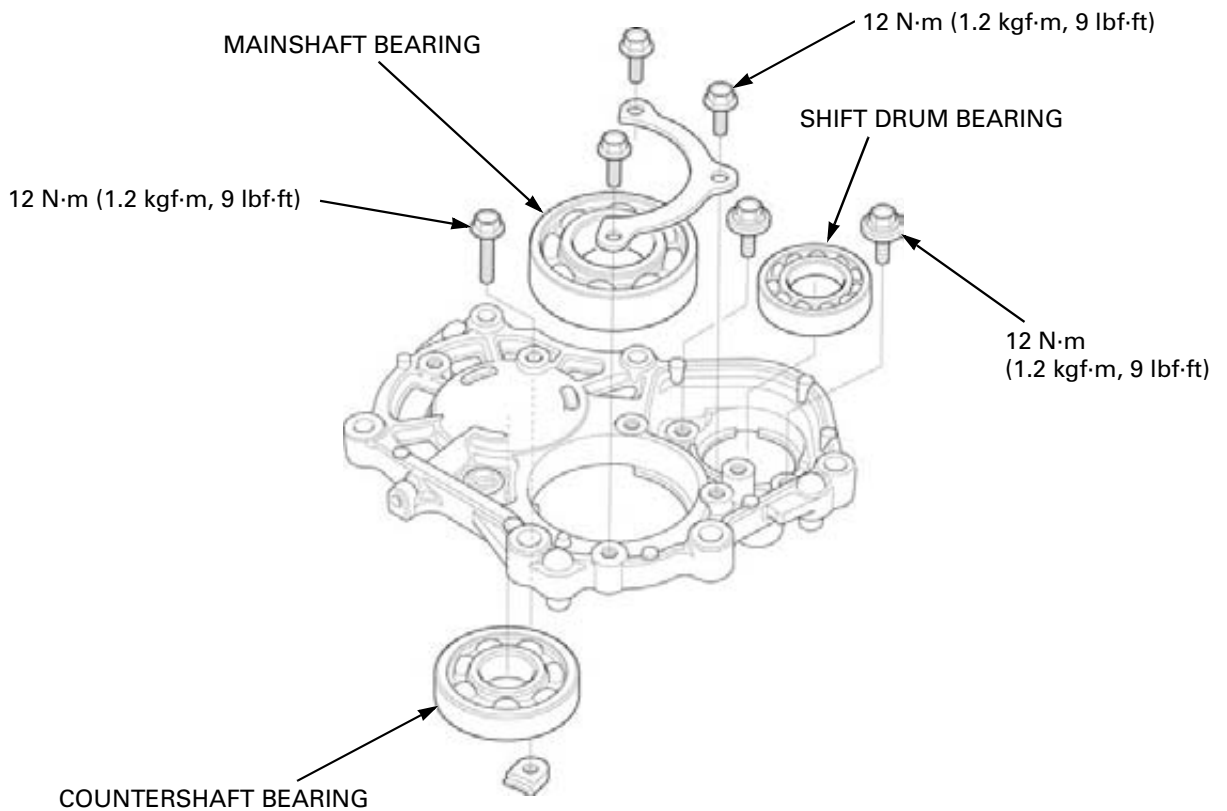

Drive the each bearing into the bearing holder using the special tools.

TOOLS:

Mainshaft bearing:

- Driver** 07749-0010000
- Attachment, 62 x 68 mm** 07746-0010500
- Pilot, 28 mm** 07746-0041100

Countershaft bearing:

- Driver** 07749-0010000
- Attachment, 52 x 55 mm** 07746-0010400
- Pilot, 20 mm** 07746-0040500

Shift drum bearing:

- Driver** 07749-0010000
- Attachment, 42 x 47 mm** 07746-0010300
- Pilot, 25 mm** 07746-0040600

Apply a locking agent to the countershaft bearing set plate bolt threads. Install the set plate and tighten the bolt to the specified torque.

TORQUE: 12 N·m (1.2 kgf·m, 9 lbf·ft)

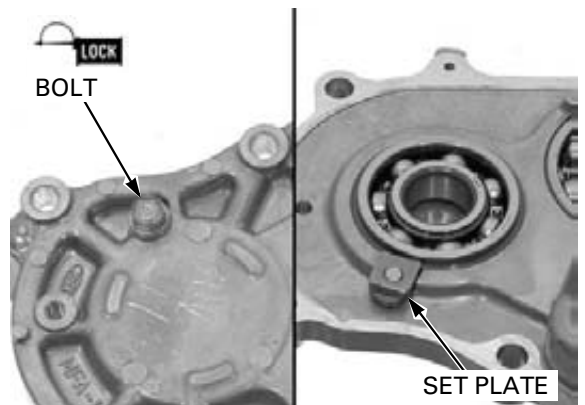
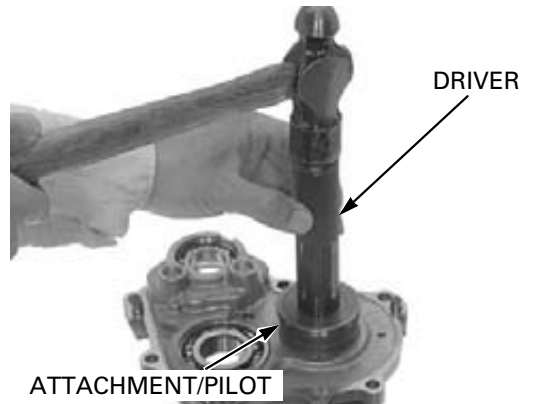

TRANSMISSION/GEARSHIFT LINKAGE

Apply a locking agent to the mainshaft bearing set plate bolt threads and shift drum bearing setting bolt threads.

Install the mainshaft bearing set plate with its "MEL OUTSIDE" mark facing out.

Install and tighten the bearing set plate bolts and setting bolts to the specified torque.

TORQUE: 12 N·m (1.2 kgf·m, 9 lbf·ft)

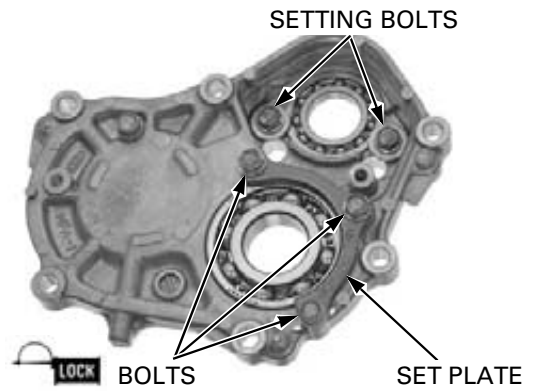

TRANSMISSION ASSEMBLY

Mainshaft:

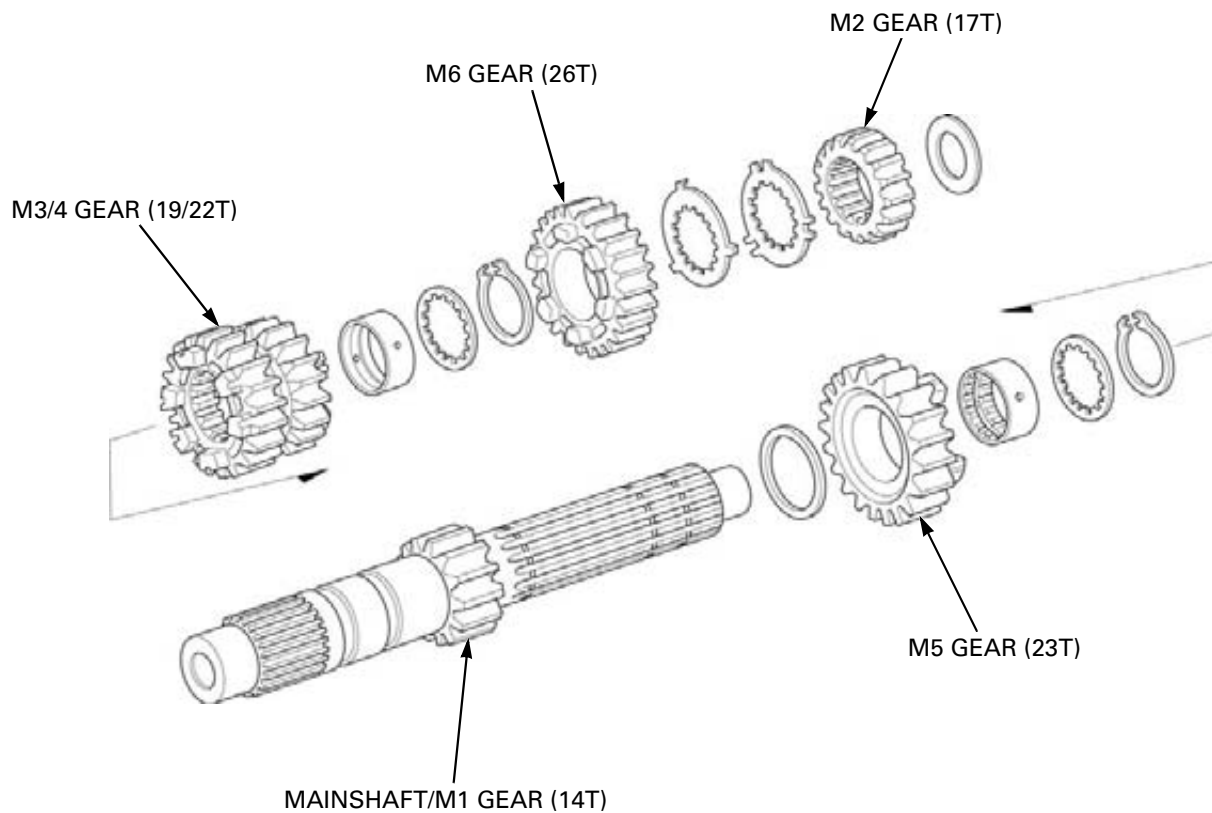

Countershaft:

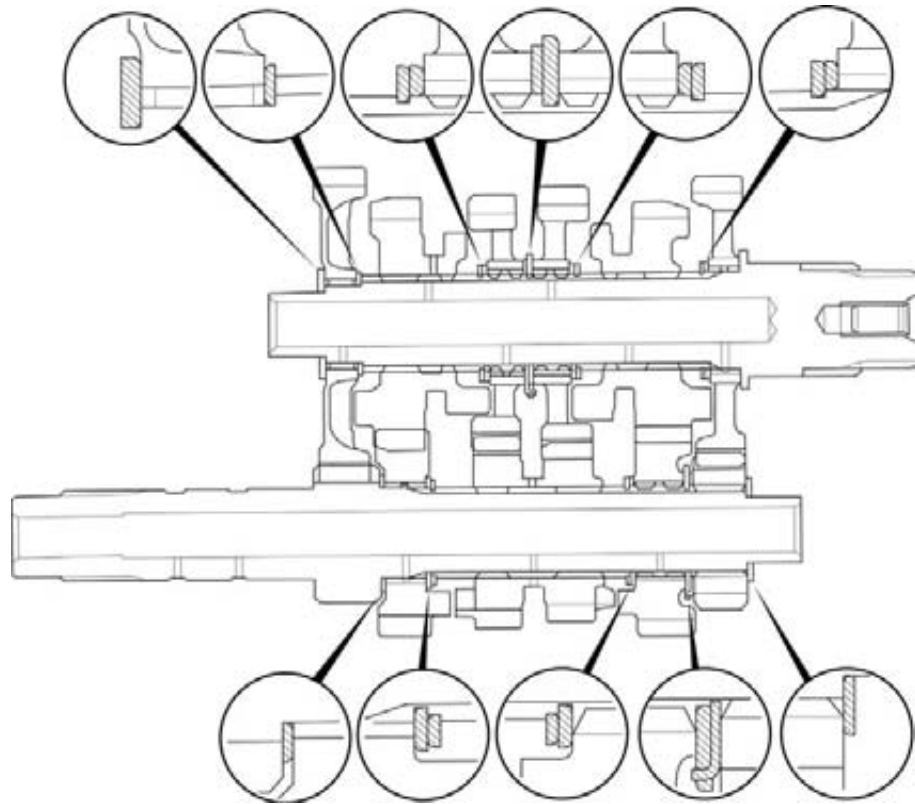
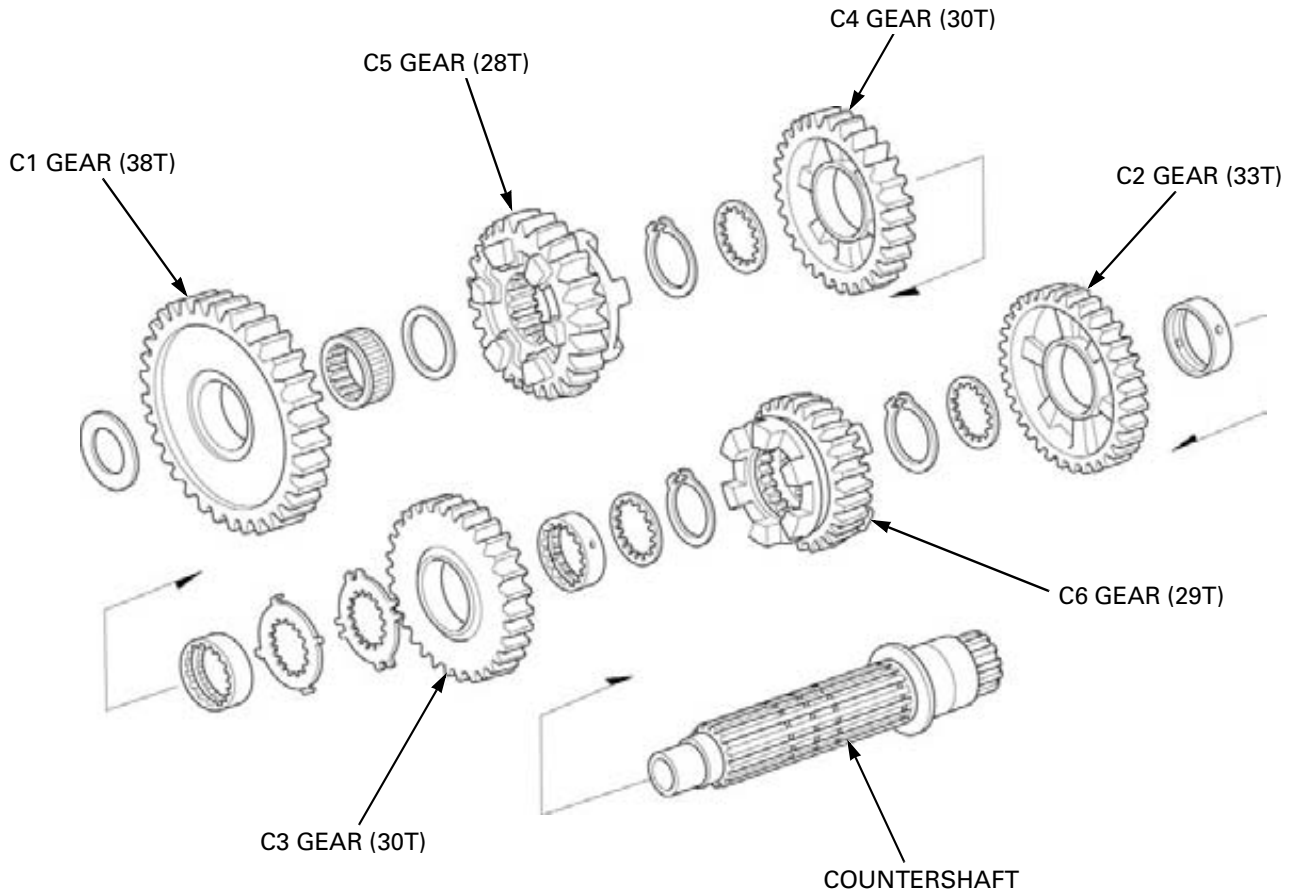

TRANSMISSION/GEARSHIFT LINKAGE

Apply clean engine oil to the gear teeth, sliding surfaces and the bushings.
Assemble the transmission gears and shafts.

- Always install the thrust washer and snap ring with the chamfered (rolled) edge facing away from the thrust load.
- Install the snap ring so that its end gap aligns with the groove in the splines.
- Make sure that the snap ring is fully seated in the shaft groove after installing it.
- Align the lock washer tabs with the spline washer grooves.

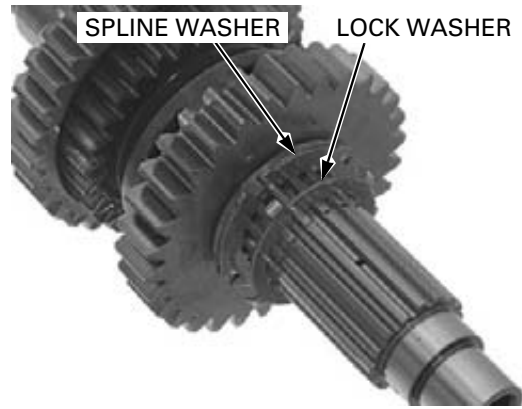

Apply molybdenum oil solution to the shift fork grooves in the M3, C5 and C6 gear.

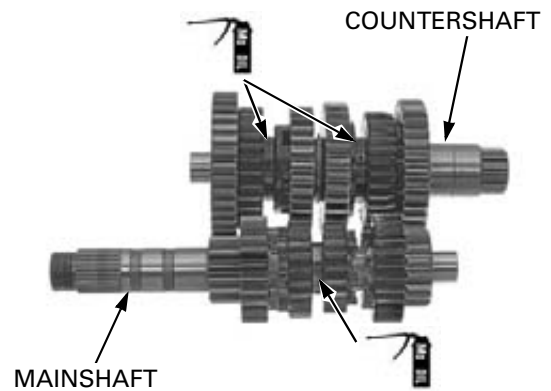

TRANSMISSION HOLDER ASSEMBLY

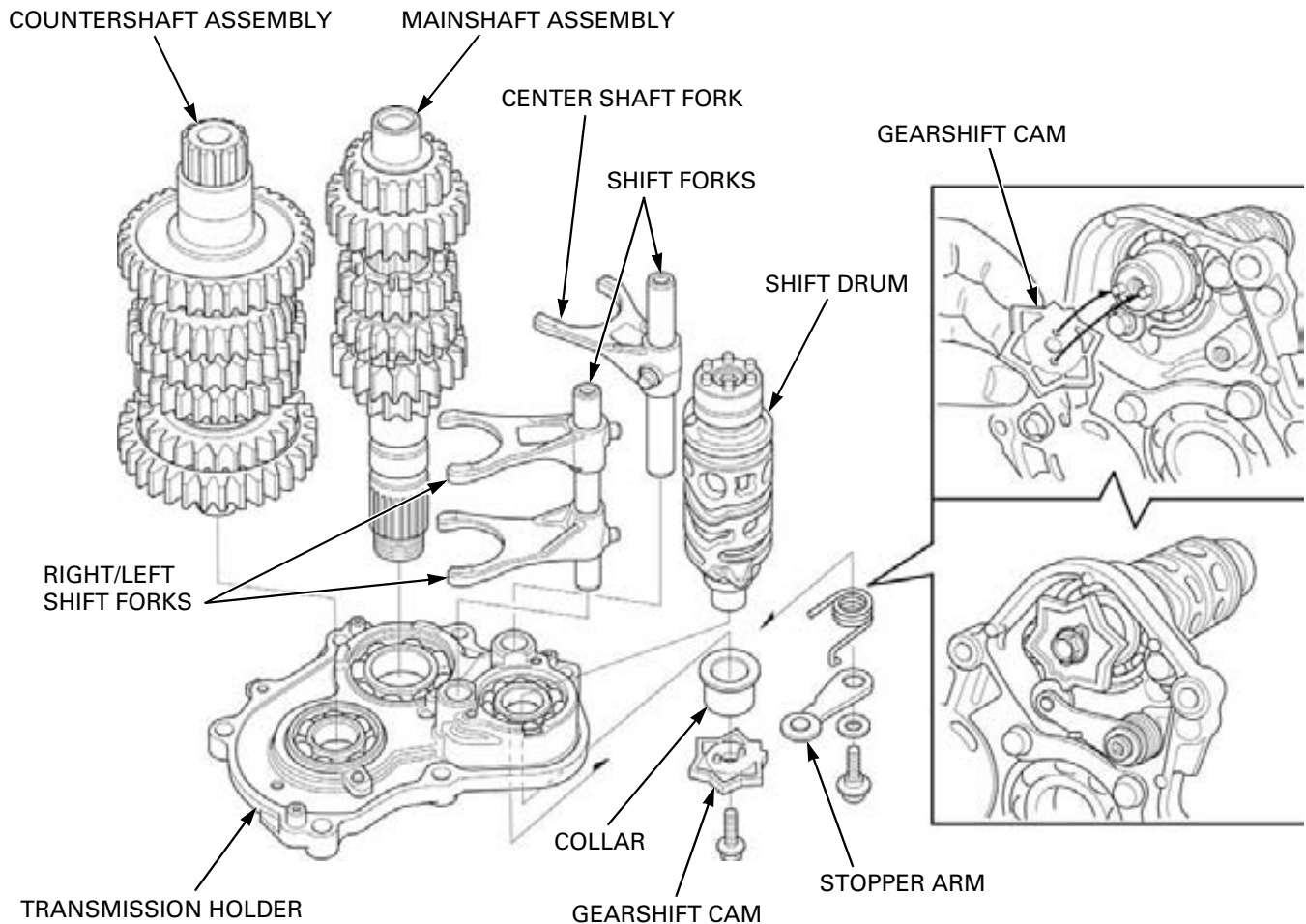

TRANSMISSION/GEARSHIFT LINKAGE

Install the shift drum into the transmission holder.

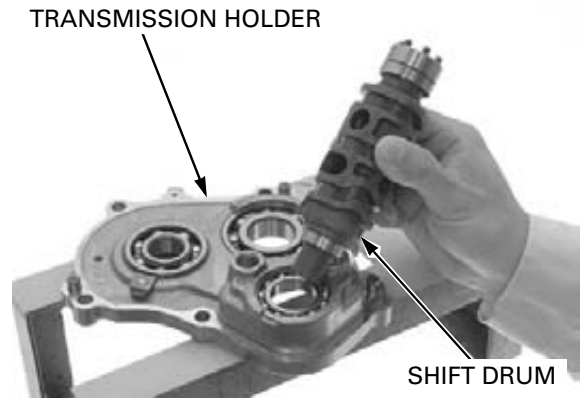

Install the flange collar with its flange facing in.

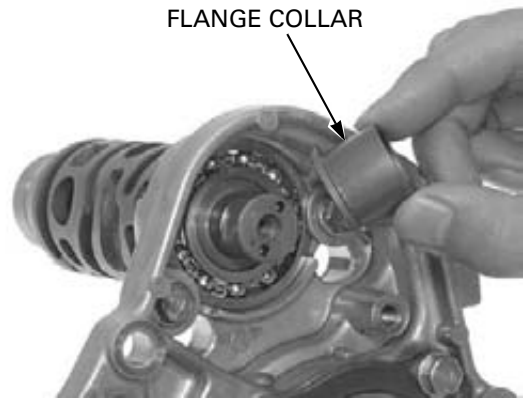

Install the dowel pins onto the gearshift cam.

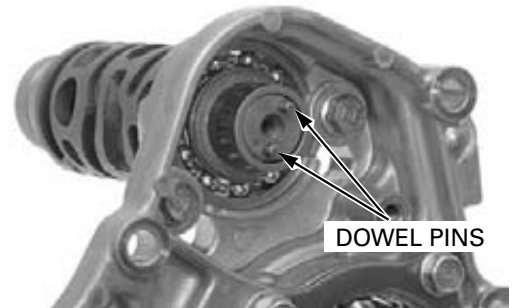

Install the gearshift cam onto the gearshift drum.
Apply a locking agent to the gearshift cam bolt threads.
Install and tighten the bolt securely.

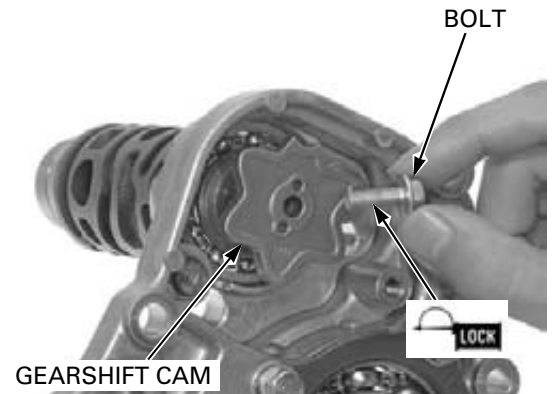

TRANSMISSION/GEARSHIFT LINKAGE

Install the following:

- Return spring
- Washer
- Stopper arm
- Pivot bolt

Tighten the stopper arm pivot bolt to the specified torque.

TORQUE: 12 N-m (1.2 kgf-m, 9 lbf-ft)

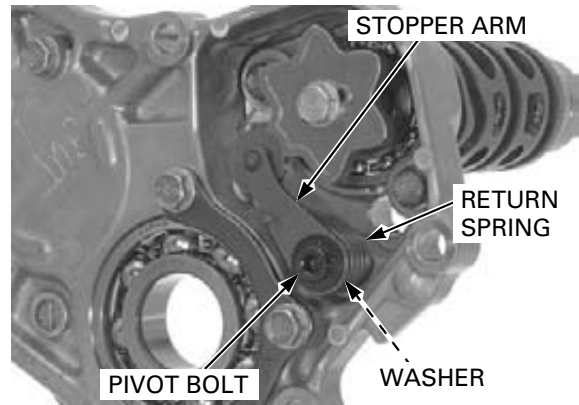

Install the mainshaft and countershaft as an assembly to the transmission holder.

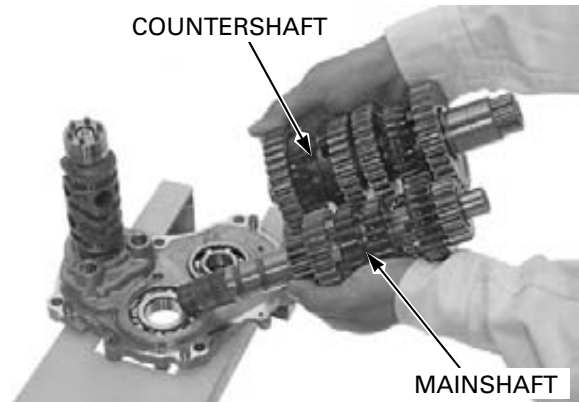

The shift forks have location marks:

- "RL" for right and left
- "C" for center

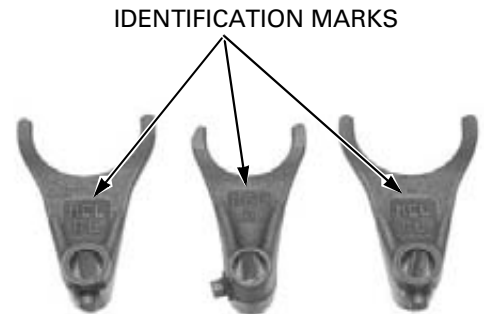

The shaft for center shift fork is shorter than that for right/left shift forks.

Install the shift fork shafts onto the transmission holder.

Install the shift forks with their identification marks facing up.

Install each shift fork and align its claw with each shifter groove.

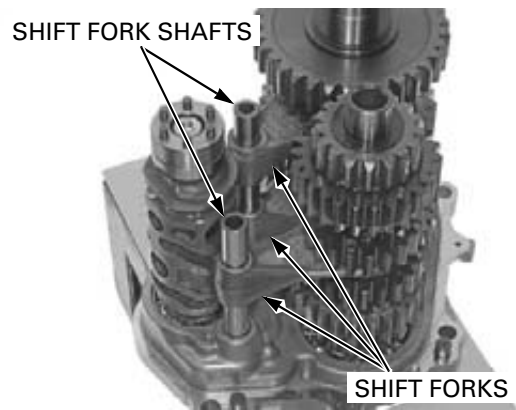

INSTALLATION

Install the oil orifice with its small I.D. side facing in.



Turn the shift drum while turning the mainshaft, and position the transmission into neutral.

Install the transmission holder and transmission assembly into the crankcase.

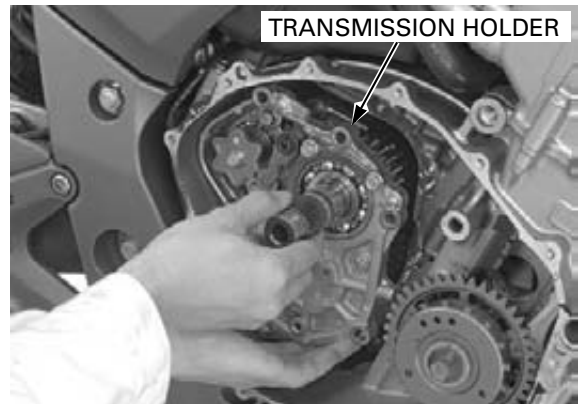

Install and tighten the bearing holder mounting bolts to the specified torque.

TORQUE: 29 N·m (3.0 kgf·m, 21 lbf·ft)

Install the following:

- Gearshift linkage (page 12-9)
- Clutch (page 10-24)
- Right crankcase cover (page 10-33)

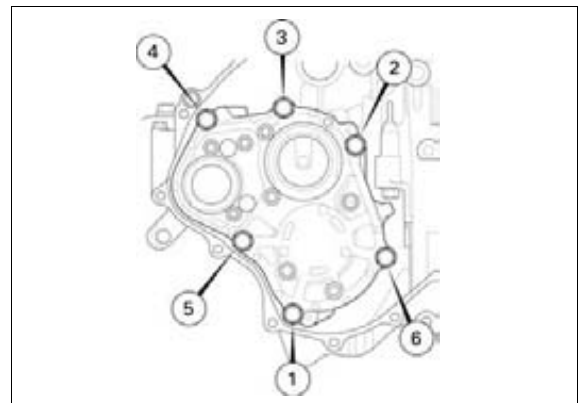

MEMO
