

9. CYLINDER HEAD/VALVES

COMPONENT LOCATION	9-2	CYLINDER HEAD INSPECTION	9-15
SERVICE INFORMATION	9-3	VALVE GUIDE REPLACEMENT	9-17
TROUBLESHOOTING	9-5	VALVE SEAT INSPECTION/ REFACING	9-18
CYLINDER COMPRESSION TEST	9-6	CYLINDER HEAD ASSEMBLY	9-21
CYLINDER HEAD COVER REMOVAL	9-6	CYLINDER HEAD INSTALLATION	9-23
CYLINDER HEAD COVER DISASSEMBLY	9-7	CAMSHAFT INSTALLATION	9-25
CAMSHAFT REMOVAL	9-8	CYLINDER HEAD COVER ASSEMBLY	9-30
CYLINDER HEAD REMOVAL	9-12	CYLINDER HEAD COVER INSTALLATION	9-31
CYLINDER HEAD DISASSEMBLY	9-13		

CYLINDER HEAD/VALVES

COMPONENT LOCATION

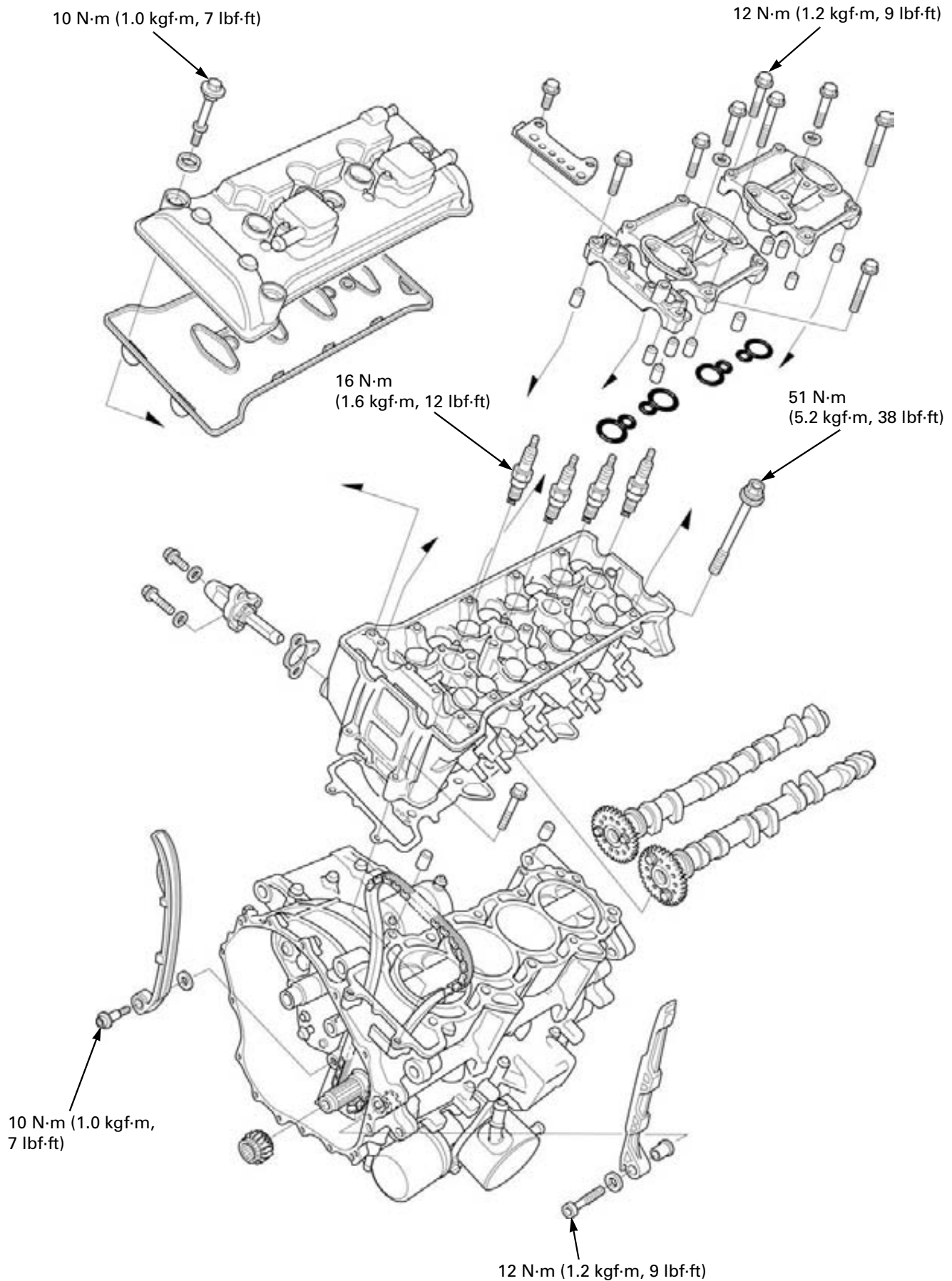

SERVICE INFORMATION

GENERAL

- This section covers service of the cylinder head, valves and camshafts.
- The camshaft services can be done with the engine installed in the frame. The cylinder head service requires engine removal.
- When disassembling, mark and store the disassembled parts to ensure that they are reinstalled in their original locations.
- Clean all disassembled parts with cleaning solvent and dry them by blowing them off with compressed air before inspection.
- Camshaft lubricating oil is fed through oil passages in the cylinder head. Clean the oil passages before assembling cylinder head.
- Be careful not to damage the mating surfaces when removing the cylinder head cover and cylinder head.

SPECIFICATIONS

Unit: mm (in)











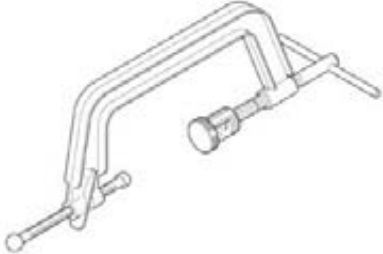

ITEM		STANDARD	SERVICE LIMIT
Cylinder compression		1,098 kPa (11.2 kgf/cm ² , 159 psi) at 350 min ⁻¹ (rpm)	–
Valve clearance		IN	0.16 ± 0.03 (0.006 ± 0.001)
		EX	0.32 ± 0.03 (0.013 ± 0.001)
Camshaft	Cam lobe height	IN	34.62 – 34.70 (1.363 – 1.366)
		EX	34.58 – 34.66 (1.361 – 1.365)
	Runout	–	0.05 (0.002)
	Oil clearance	0.020 – 0.062 (0.0008 – 0.0024)	0.10 (0.004)
Valve lifter	Valve lifter O.D.	25.978 – 25.993 (1.0228 – 1.0233)	25.97 (1.022)
	Valve lifter bore I.D.	26.010 – 26.026 (1.0240 – 1.0246)	26.04 (1.025)
Valve, valve guide	Valve stem O.D.	IN	4.475 – 4.490 (0.1762 – 0.1768)
		EX	4.465 – 4.480 (0.1758 – 0.1764)
	Valve guide I.D.	4.500 – 4.512 (0.1772 – 0.1776)	4.540 (0.1787)
	Stem-to-guide clearance	IN	0.010 – 0.037 (0.0004 – 0.0015)
		EX	0.020 – 0.047 (0.0008 – 0.0019)
	Valve guide projection above cylinder head	16.0 – 16.3 (0.63 – 0.64)	–
	Valve seat width	0.90 – 1.10 (0.035 – 0.043)	1.5 (0.06)
Valve spring free length	39.55 (1.557)	38.76 (1.526)	
Cylinder head warpage		–	0.10 (0.004)

TORQUE VALUES

Cylinder head mounting bolt	51 N·m (5.2 kgf·m, 38 lbf·ft)	Apply molybdenum disulfide oil to the threads and seating surface.
Camshaft holder flange bolt	12 N·m (1.2 kgf·m, 9 lbf·ft)	
Cylinder head sealing bolt	28 N·m (2.9 kgf·m, 21 lbf·ft)	Apply a locking agent to the threads.
Cylinder head cover bolt	10 N·m (1.0 kgf·m, 7 lbf·ft)	
PAIR reed valve cover bolt	12 N·m (1.2 kgf·m, 9 lbf·ft)	Apply a locking agent to the threads.
Cam sprocket flange knock bolt	20 N·m (2.0 kgf·m, 15 lbf·ft)	Apply a locking agent to the threads.
Cam chain tensioner pivot bolt	10 N·m (1.0 kgf·m, 7 lbf·ft)	Apply a locking agent to the threads.
Cam chain guide torx bolt	12 N·m (1.2 kgf·m, 9 lbf·ft)	Apply a locking agent to the threads.
Exhaust pipe stud bolt	See page 3-13	

CYLINDER HEAD/VALVES

TOOLS

<p>Compression gauge attachment 07RMJ-MY50100</p>  <p>or equivalent commercially available.</p>	<p>Cam chain tensioner holder 07ZMG-MCAA400</p> 	<p>Valve spring compressor 07757-0010000</p> 
<p>Valve spring compressor attachment 07959-KM30101</p> 	<p>Tappet hole protector 07HMG-MR70002</p> 	<p>Valve guide driver 07HMD-ML00101</p> 
<p>Valve guide driver 07743-0020000</p> 	<p>Valve guide reamer, 4.5 mm 07HMH-ML00101</p> 	<p>Valve seat cutter, 29 mm (45° IN) 07780-0010300</p>  <p>or equivalent commercially available.</p>
<p>Valve seat cutter, 24.5 mm (45° EX) 07780-0010100</p>  <p>or equivalent commercially available.</p>	<p>Flat cutter, 30 mm (32° IN) 07780-0012200</p>  <p>or equivalent commercially available.</p>	<p>Flat cutter, 27 mm (32° EX) 07780-0013300</p>  <p>or equivalent commercially available.</p>

<p>Interior cutter, 30 mm (60° IN) 07780-0014000</p>  <p>or equivalent commercially available.</p>	<p>Interior cutter, 26 mm (60° EX) 07780-0014500</p>  <p>or equivalent commercially available.</p>	<p>Cutter holder, 4.5 mm 07781-0010600</p>  <p>or equivalent commercially available.</p>
---	---	---

TROUBLESHOOTING

- Engine top-end problems usually affect engine performance. These problem can be diagnosed by a compression test or by tracing engine noises to the top-end with a sounding rod stethoscope.
- If the performance is poor at low speeds, check for white smoke in the crankcase breather hose. If the hose is smoky, check for a seized piston ring (page 13-17).

Compression too low, hard starting or poor performance at low speed

- Valves:
 - Incorrect valve adjustment
 - Burned or bent valve
 - Incorrect valve timing
 - Broken valve spring
 - Uneven valve seating
- Cylinder head:
 - Leaking or damaged head gasket
 - Warped or cracked cylinder head
- Worn cylinder, piston or piston rings (page 13-17)

Compression too high, overheating or knocking

- Excessive carbon build-up on piston crown or on combustion chamber

Excessive smoke

- Cylinder head:
 - Worn valve stem or valve guide
 - Damaged stem seal
- Worn cylinder, piston or piston rings (page 13-17)

Excessive noise

- Cylinder head:
 - Incorrect valve adjustment
 - Sticking valve or broken valve spring
 - Damaged or worn camshaft
 - Loose or worn cam chain
 - Worn or damaged cam chain
 - Worn or damaged cam chain tensioner
 - Worn cam sprocket teeth
- Worn cylinder, piston or piston rings (page 13-17)

Rough idle

- Low cylinder compression

CYLINDER HEAD/VALVES

CYLINDER COMPRESSION TEST

Warm the engine to normal operating temperature.
Stop the engine and remove the all spark plug caps and spark plugs (page 4-8).
Lift and support the fuel tank (page 4-5).
Disconnect the fuel pump unit 3P (Black) connector.

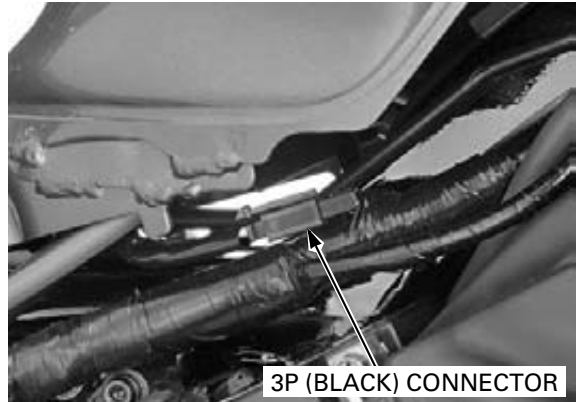

Install a compression gauge into the spark plug hole.

TOOL:

Compression gauge attachment

07RMJ-MY50100 or equivalent commercially available

Open the throttle all the way and crank the engine with the starter motor until the gauge reading stops rising.

The maximum reading is usually reached within 4 – 7 seconds.

Compression pressure:

1,098 kPa (11.2 kgf/cm², 159 psi) at 350 min⁻¹ (rpm)

Low compression can be caused by:

- Blown cylinder head gasket
- Improper valve adjustment
- Valve leakage
- Worn piston ring or cylinder

High compression can be caused by:

- Carbon deposits in combustion chamber or on piston head

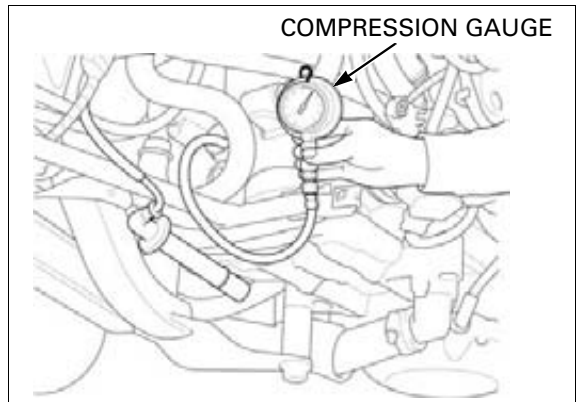

CYLINDER HEAD COVER REMOVAL

Remove the fuel tank (page 6-57).
Disconnect the spark plug caps (page 4-8).

Remove the crankcase breather hose.
Disconnect the PAIR air hoses from the cylinder head cover and remove the PAIR control solenoid valve (page 6-84).

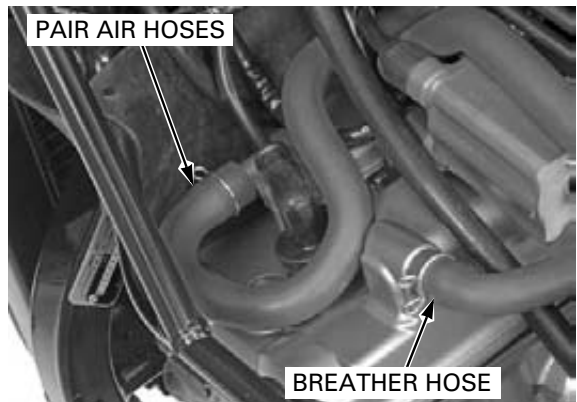

Remove the cylinder head cover bolts.
Remove the cylinder head cover from the cylinder head.

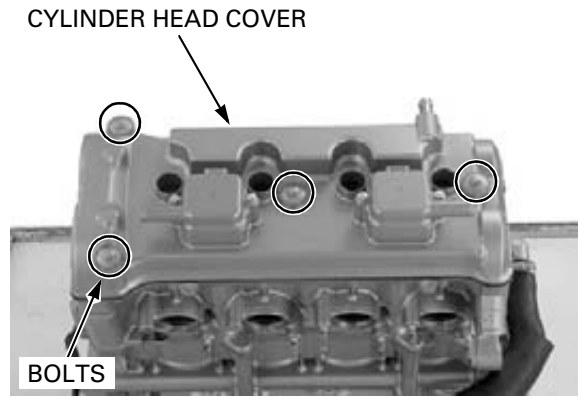

CYLINDER HEAD COVER DISASSEMBLY

Remove the cylinder head cover packing.

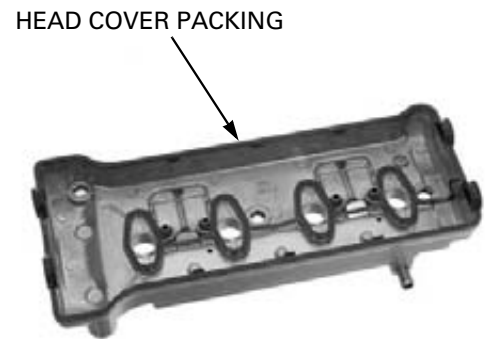

Remove the bolts and PAIR check valve cover.

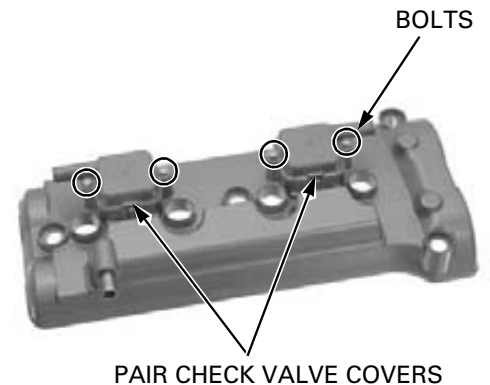

Remove the PAIR check valves from the cylinder head cover.

Check the PAIR check valve for wear or damage,
replace if necessary.

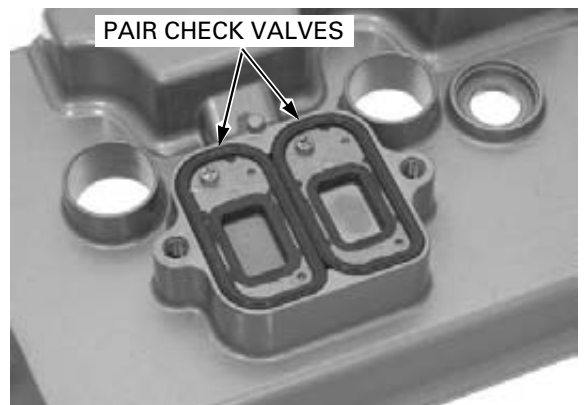

CYLINDER HEAD/VALVES

Remove the port plates from the cylinder head cover.

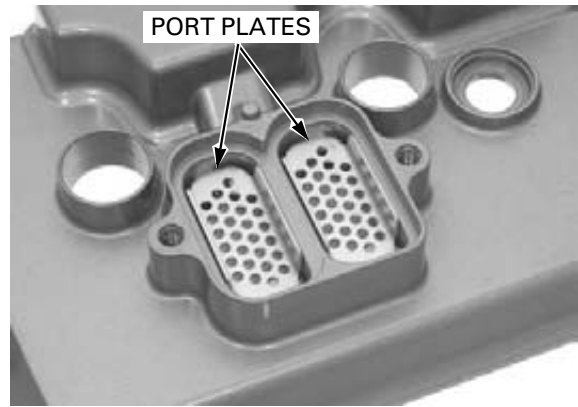

CAMSHAFT REMOVAL

Remove the cylinder head cover (page 9-6).
Remove the timing hole cap and O-ring.

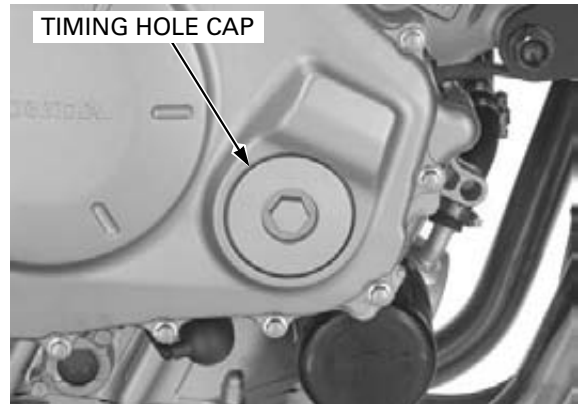

Turn the crankshaft clockwise, align the "T" mark on the starter clutch outer with the index notch on the right crankcase cover.

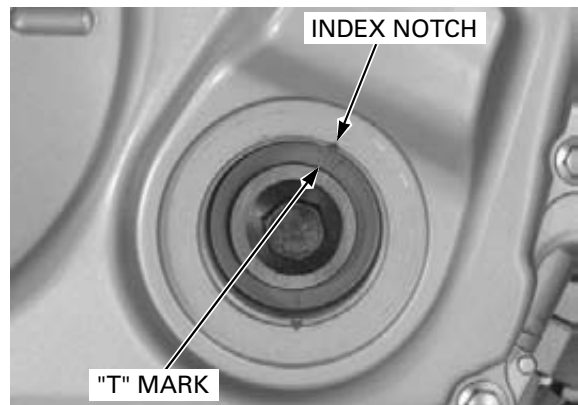

The timing marks ("IN" and "EX") on the cam sprockets must be flush with the cylinder head surface and facing outward as shown.

If the timing marks on the cam sprocket are facing inward, turn the crankshaft clockwise one full turn (360°) and realign the timing marks with the cylinder head surface so they are facing outward.

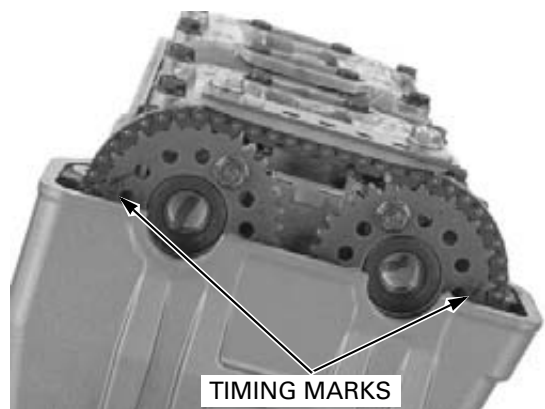

Remove the cam chain tensioner lifter sealing bolt and sealing washer.

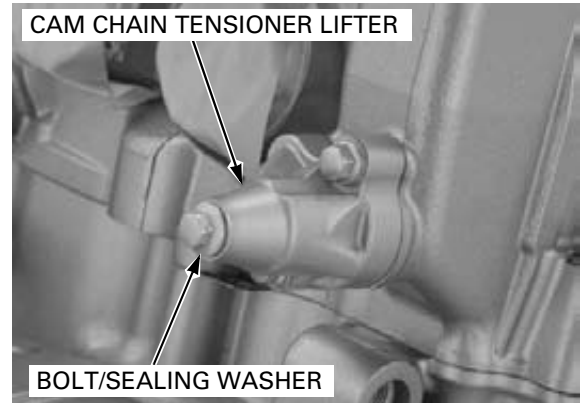

Turn the tensioner lifter shaft fully in (clockwise) and secure it using the special tool to prevent damaging the cam chain.

TOOL:

Cam chain tensioner holder 07ZMG-MCAA400

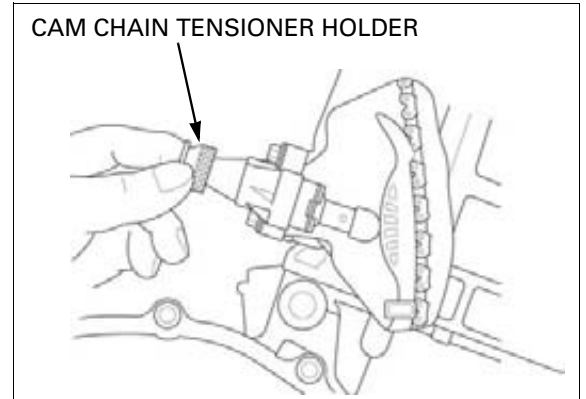

Remove the bolts and cam chain guide B.

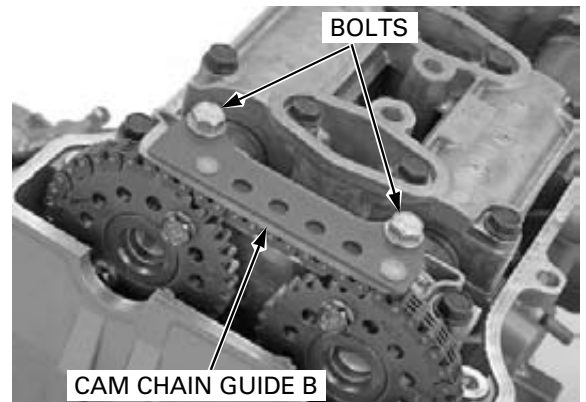

It is not necessary to remove the cam sprocket from the camshaft except when replacing the camshaft and/or cam sprocket.

If you plan to replace the camshaft and/or cam sprocket, loosen and remove the cam sprocket bolts as follows:

Be careful not to drop the cam sprocket bolts and cam sprocket into the crankcase.

- Remove the cam sprocket bolts from the intake and exhaust camshafts.

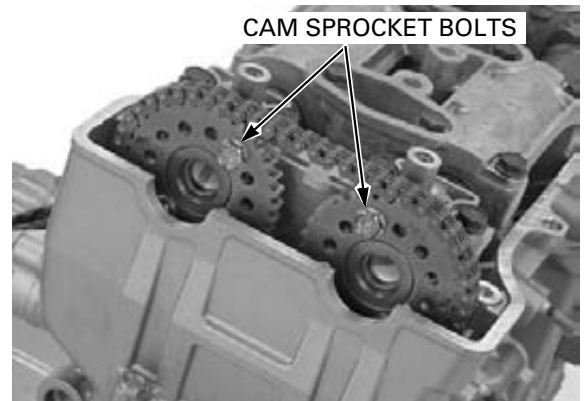

CYLINDER HEAD/VALVES

- Turn the crankshaft clockwise one full turn (360°), remove the other cam sprocket bolts from the camshafts.
- Remove the cam sprockets from the camshafts.

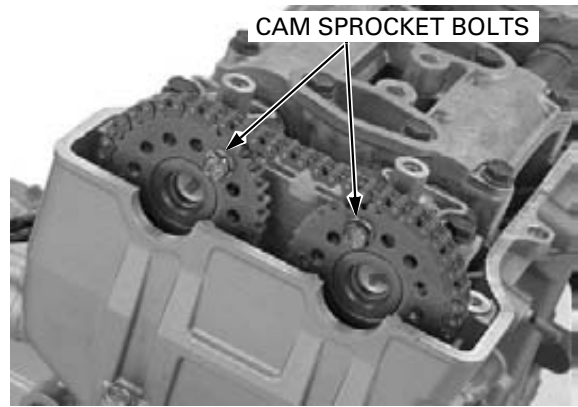

Suspend the cam chain with a piece of wire to prevent the chain from falling into the crankcase.

Loosen and remove the camshaft holder bolts/washers, then remove the camshaft holders and camshafts.

NOTE:

From outside to inside, loosen the bolts in a criss-cross pattern in several steps or the camshaft holder might break.

Do not forcibly remove the dowel pins from the camshaft holders.

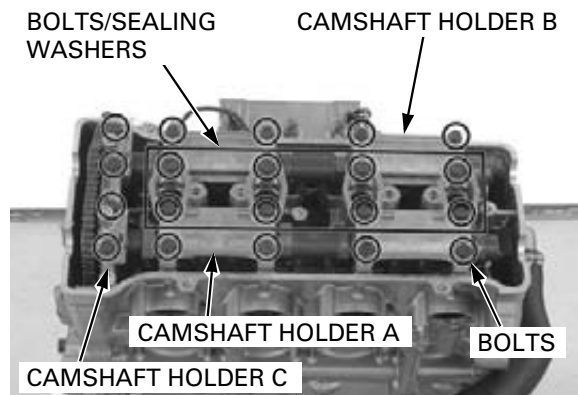

Remove the valve lifters and shims.

- Be careful not to damage the valve lifter bore.
- Shim may stick to the inside of the valve lifter. Do not allow the shims to fall into the crankcase.
- Mark all valve lifters and shims to ensure correct reassembly in their original locations.
- The valve lifter can be easily removed with a valve lapping tool or magnet.
- The shims can be easily removed with a tweezers or magnet.

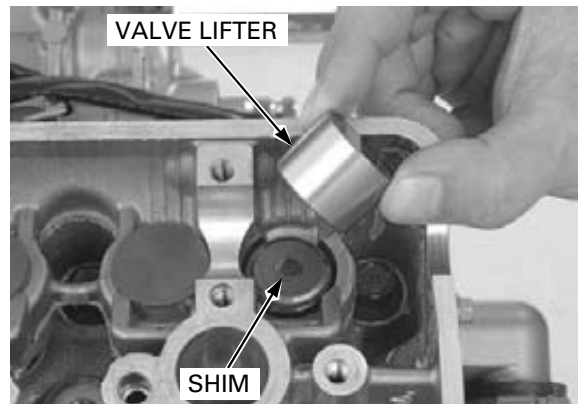

INSPECTION

CAMSHAFT

Check the cam and journal surfaces of the camshaft for scoring, scratches or evidence of insufficient lubrication.

Check the oil holes in the camshaft for clogging.

Support both sides of the camshaft (at journals) with V-blocks and check the camshaft run out with a dial gauge.

SERVICE LIMIT: 0.05 mm (0.002 in)

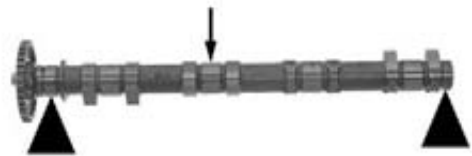

Using a micrometer, measure each cam lobe height.

SERVICE LIMITS:

IN: 34.60 mm (1.362 in)

EX: 34.56 mm (1.361 in)



CAMSHAFT HOLDERS

Inspect the journals of the each camshaft holder for scoring, scratches, or evidence of insufficient lubrication.

Inspect the oil orifices of the holders for clogging.

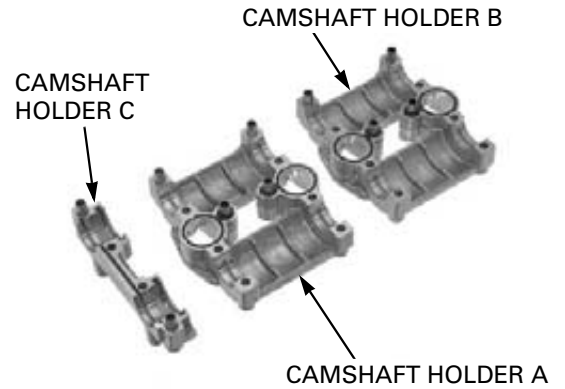

CAMSHAFT OIL CLEARANCE

Do not rotate the camshaft when using plastigauge.

Wipe any oil from the journals of the camshaft, cylinder head and camshaft holders. Lay a strip of plastigauge lengthwise on top of each camshaft journal.

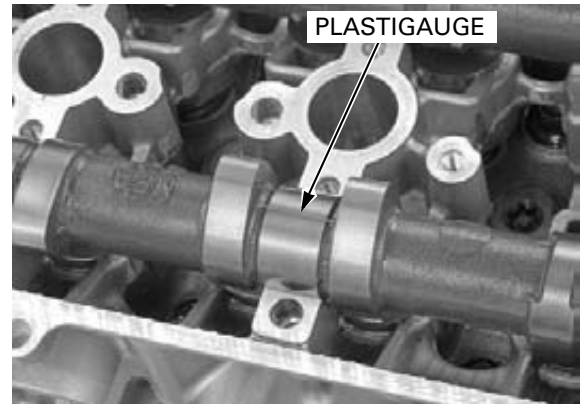

Be sure the dowel pins in the camshaft holder align the holes in the cylinder head.

Install the each camshaft holder to the correct locations with the identification marks.

- "R" mark: center camshaft holder (Holder A)
- "L" mark: left camshaft holder (Holder B)

Apply engine oil to the threads and seating surfaces of the camshaft holder bolts.

Install the twenty holder bolts with the eight sealing washers.

Finger tighten the bolts.

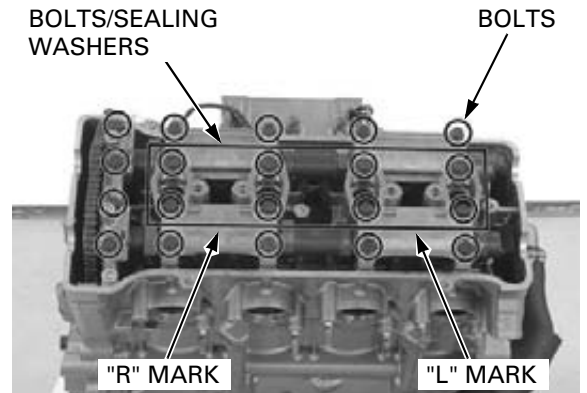

CYLINDER HEAD/VALVES

First gradually tighten the four bolts (No.1 – No.2 – No.7 – No.8) in the numerical order cast on the camshaft holders.

Gradually tighten the other camshaft holder bolts until the camshaft holders lightly contact the cylinder head surface.

NOTICE

Failure to tighten the camshaft holder in a crisscross pattern might cause a camshaft holder to break.

Tighten all camshaft holder bolts in the numerical order cast on the camshaft holders.

TORQUE: 12 N·m (1.2 kgf·m, 9 lbf·ft)

Remove the camshaft holders and measure the width of each plastigauge.

The widest thickness determines the oil clearance.

SERVICE LIMIT: 0.10 mm (0.004 in)

When the service limits are exceeded, replace the camshaft and recheck the oil clearance.

Replace the cylinder head and camshaft holders as a set if the clearance still exceeds the service limit.

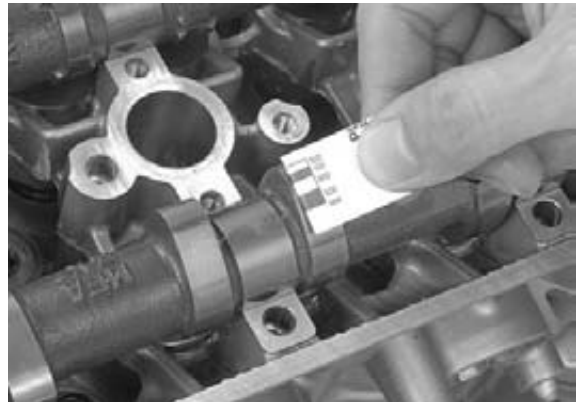
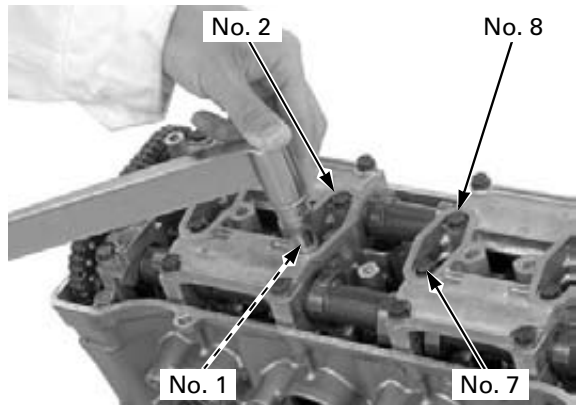

CYLINDER HEAD REMOVAL

Remove the engine from the frame (page 8-4).

Remove the camshafts (page 9-8).

Tilt the engine and drain the coolant from the cylinder head and cylinder.

Remove the bolts, sealing washers, cam chain tensioner lifter and gasket.

Remove the two 6 mm bolts.

Remove the ten 9 mm bolts/washers.

Remove the cylinder head.

Loosen the 9 mm bolts in a crisscross pattern in two or three steps.

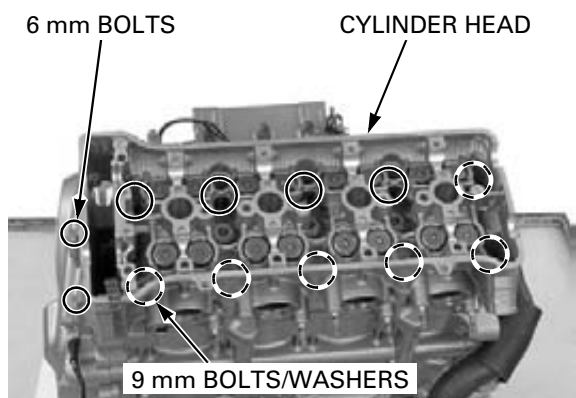
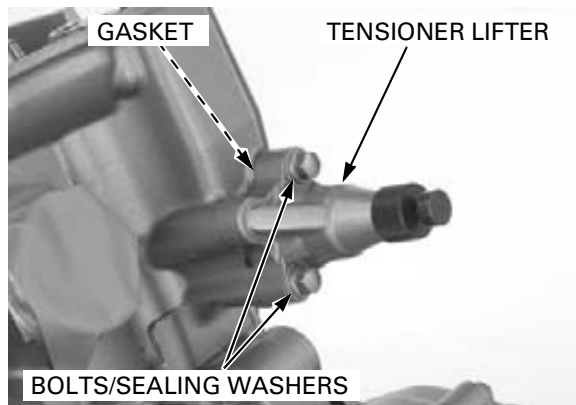

CYLINDER HEAD/VALVES

Remove the gasket and dowel pins.

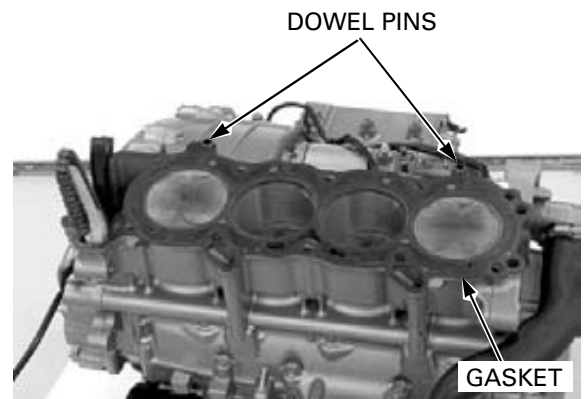

Remove the following:

- Right crankcase cover (page 10-15)
- Starter clutch (page 10-28)

Remove the torx bolt, washer, cam chain guide and pivot collar.

Remove the socket bolt, cam chain tensioner and washer.

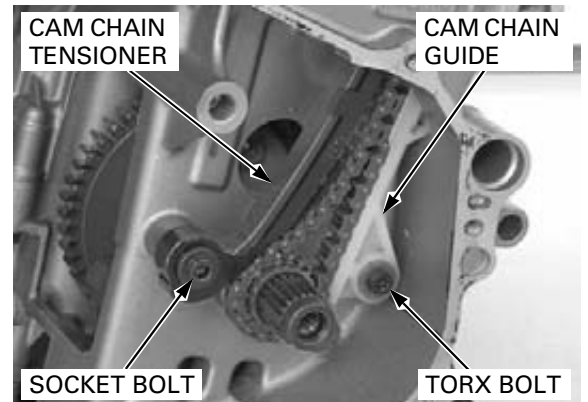

Remove the cam chain and timing sprocket from the crankshaft.

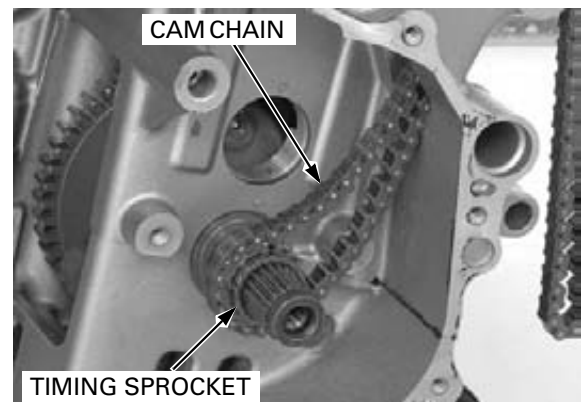

CYLINDER HEAD DISASSEMBLY

Remove the bolt and water hose joint from the cylinder head.

Remove the O-ring from the water hose joint.

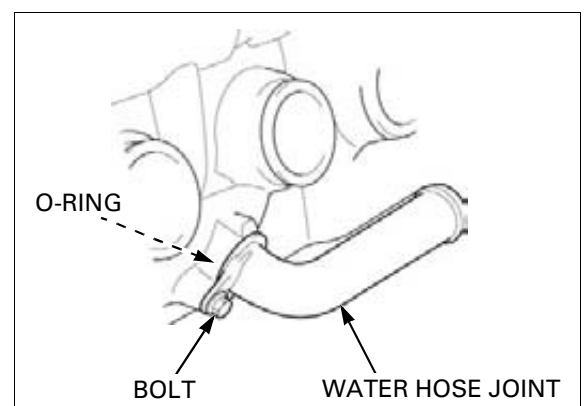

CYLINDER HEAD/VALVES

Remove the cylinder head (page 9-12).

Remove the spark plugs from the cylinder head.

Install the tappet hole protector into the valve lifter bore.

TOOL:

Tappet hole protector **07HMG-MR70002**

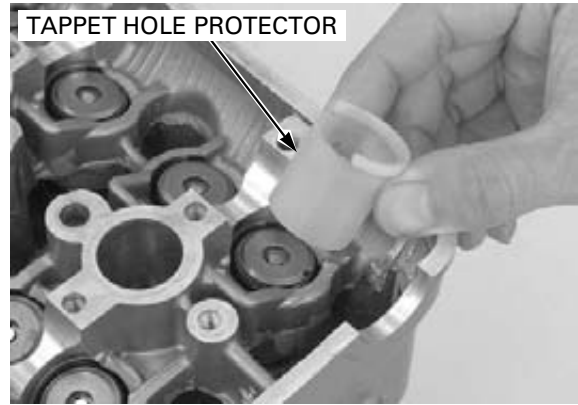

An equivalent tool can easily be made from a plastic 35 mm film container as shown.

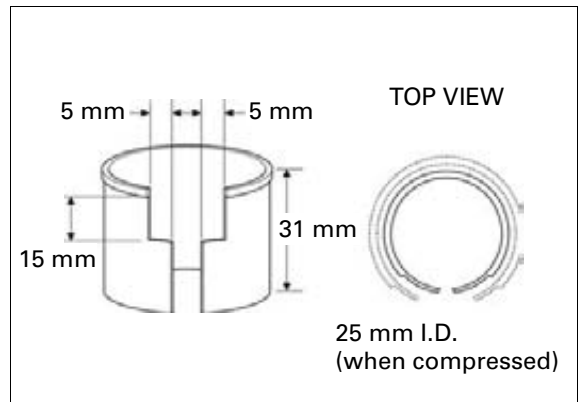

To prevent loss of tension, do not compress the valve springs more than necessary to remove the cotters.

Remove the valve spring cotters using the special tools as shown.

TOOLS:

Valve spring compressor **07757-0010000**

Valve spring compressor attachment **07959-KM30101**

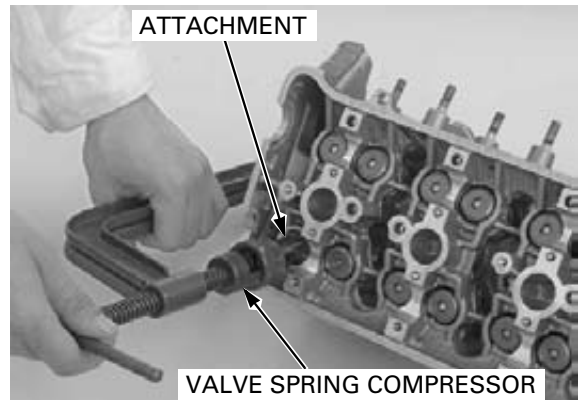

Mark all parts during disassembly so they can be placed back in their original locations.

Remove the following:

- Spring retainer
- Valve spring
- Valve
- Stem seal
- Valve spring seat

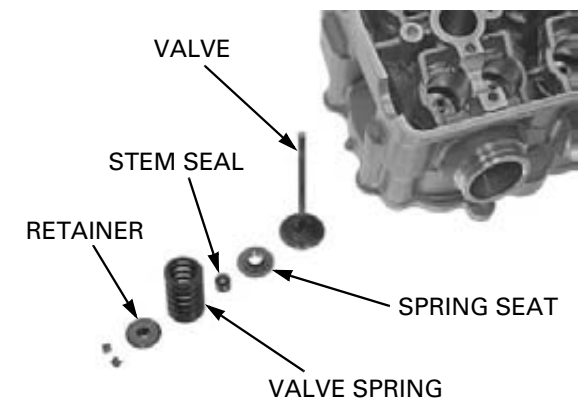

CYLINDER HEAD INSPECTION

CYLINDER HEAD

Avoid damaging the gasket surface. Remove carbon deposits from the combustion chambers. Check the spark plug hole and valve areas for cracks.

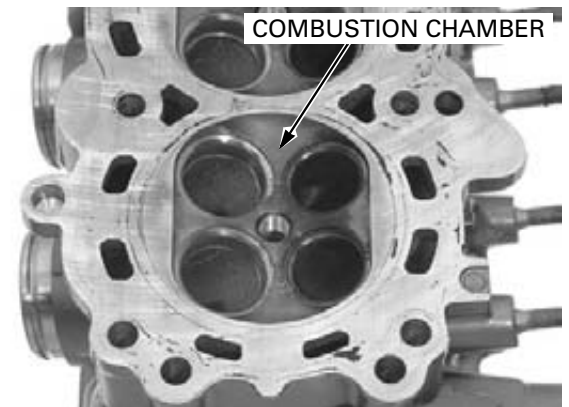

Check the cylinder head for warpage with a straight edge and feeler gauge.

SERVICE LIMIT: 0.10 mm (0.004 in)



VALVE LIFTER BORE

Inspect each valve lifter bore for scratches or abnormal wear. Measure the each valve lifter bore I.D.

SERVICE LIMIT: 26.04 mm (1.025 in)



VALVE LIFTER

Inspect each valve lifter for scratches or abnormal wear. Measure the each valve lifter O.D.

SERVICE LIMIT: 25.97 mm (1.022 in)



CYLINDER HEAD/VALVES

VALVE SPRING

Measure the free length of the valve springs.

SERVICE LIMITS:

IN/EX: 38.76 mm (1.526 in)

Replace the springs if they are shorter than the service limits.



VALVE/VALVE GUIDE

Check that the valve moves smoothly in the guide. Inspect each valve for bending, burning or abnormal stem wear.

Measure and record each valve stem O.D.

SERVICE LIMITS:

IN: 4.465 mm (0.1758 in)

EX: 4.455 mm (0.1754 in)



Ream the guides to remove any carbon deposits before checking clearances. Insert the reamer from the combustion chamber side of the cylinder head and always rotate the reamer clockwise.

TOOL:

Valve guide reamer, 4.5 mm 07HMH-ML00101

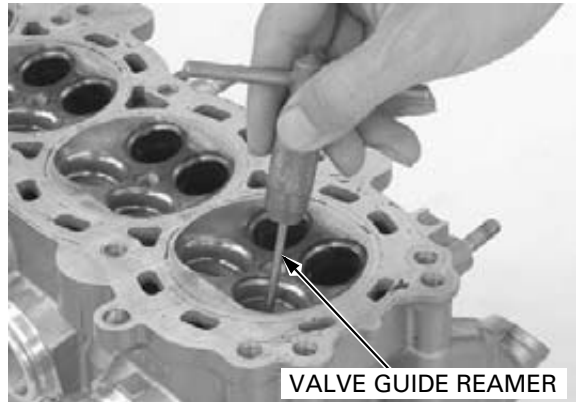

Measure and record each valve guide I.D.

SERVICE LIMIT: IN/EX: 4.540 mm (0.1787 in)

Subtract each valve stem O.D. from the corresponding guide I.D. to obtain the stem-to-guide clearance.

SERVICE LIMIT:

IN: 0.075 mm (0.0030 in)

EX: 0.085 mm (0.0033 in)



Reface the valve seats whenever the valve guides are replaced (page 9-19).

If the stem-to-guide clearance is out of standard, determine if a new guide with standard dimensions would bring the clearance within tolerance. If so, replace any guides as necessary and ream to fit. If the stem-to-guide clearance exceeds the service limit with the new guides, replace the valves and guides.

CAM CHAIN TENSIONER/CAM CHAIN GUIDE

Inspect the cam chain tensioner and cam chain guide for excessive wear or damage, replace them if necessary.

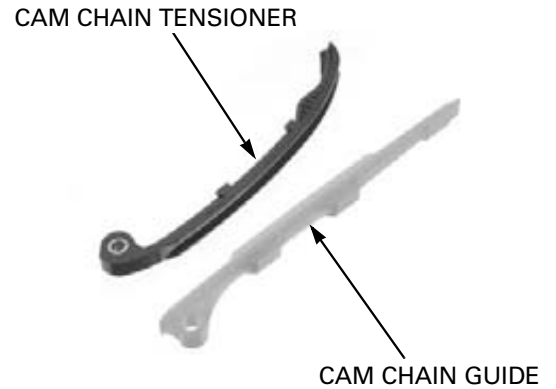

Inspect the cam chain tensioner B for excessive wear or damage, replace it if necessary.

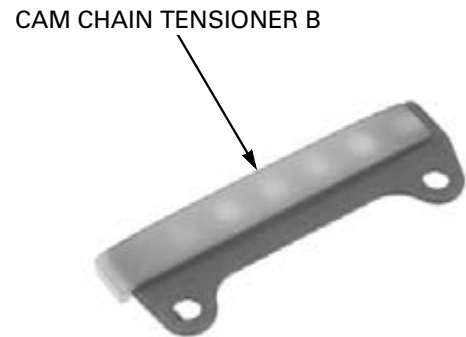

CAM CHAIN TENSIONER LIFTER

Check the cam chain tensioner lifter operation as follows.

The tensioner shaft should not go into the body when it is pushed.

When it is turned clockwise with the cam chain tensioner holder or a screwdriver, the tensioner shaft should be pulled into the body. The shaft springs out of the body as soon as the stopper tool is released.

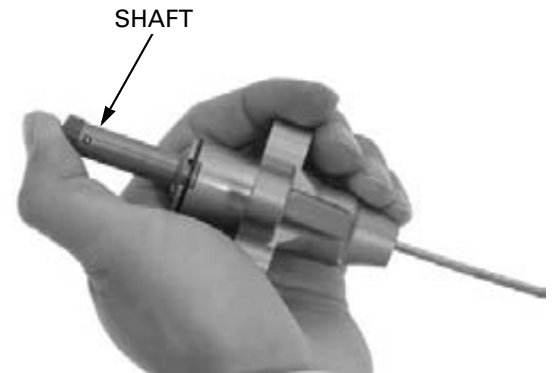

VALVE GUIDE REPLACEMENT

Chill the replacement valve guides in the freezer section of a refrigerator for about an hour.

Do not use a torch to heat the cylinder head; it may cause warping.

Heat the cylinder head to 100 – 150°C (212 – 300°F) with a hot plate or oven.

To avoid burns, wear heavy gloves when handling the heated cylinder head.

Support the cylinder head and drive out the valve guides from combustion chamber side of the cylinder head.

TOOL:
Valve guide driver **07HMD-ML00101**



CYLINDER HEAD/VALVES

Drive in the guides to the specified depth from the top of the cylinder head.

TOOL:

Valve guide driver **07743-002000**

SPECIFIED DEPTH:

IN/EX: 16.0 – 16.3 mm (0.63 – 0.64 in)

Let the cylinder head cool to room temperature.

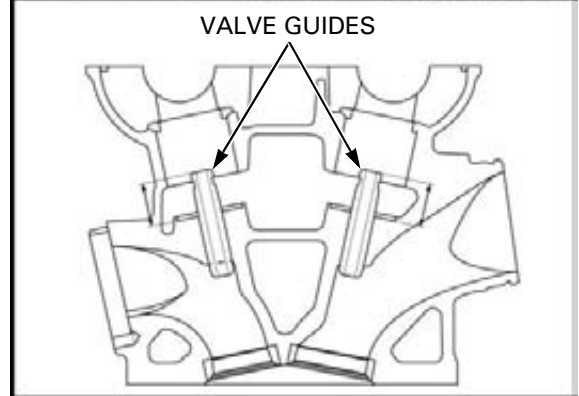
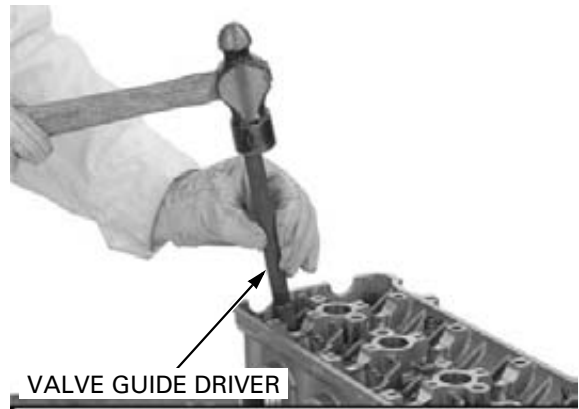

Use cutting oil on the reamer during this operation.

Ream the new valve guides after installation. Insert the reamer from the combustion chamber side of the head and also always rotate the reamer clockwise.

TOOL:

Valve guide reamer, 4.5 mm **07HMH-ML00101**

Clean the cylinder head thoroughly to remove any metal particles.
Reface the valve seat (page 9-19).

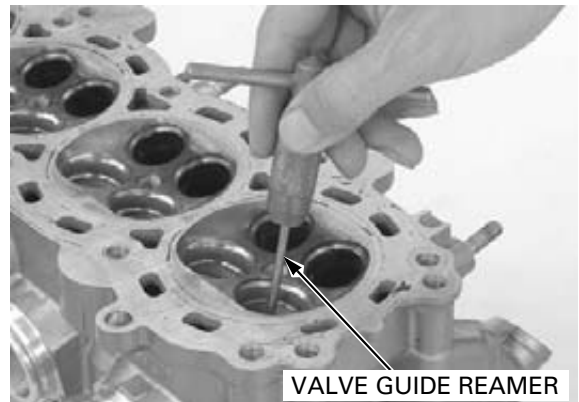

VALVE SEAT INSPECTION/REFACING

Clean the intake and exhaust valves thoroughly to remove carbon deposits.
Apply a light coating of Prussian Blue to the valve seats.
Tap the valves and seats using a rubber hose or other hand-lapping tool.

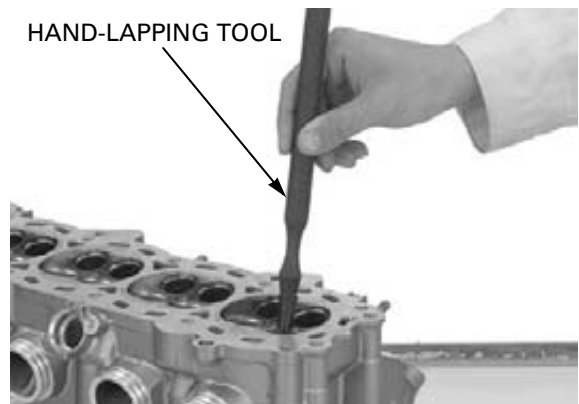

Remove the valve and inspect the valve seat face. The valve seat contact should be within the specified width and even all around the circumference.

STANDARD:

IN/EX: 0.90 – 1.10 mm (0.035 – 0.043 in)

SERVICE LIMIT:

IN/EX: 1.5 mm (0.06 in)

If the seat width is not within specification, reface the valve seat (page 9-19).

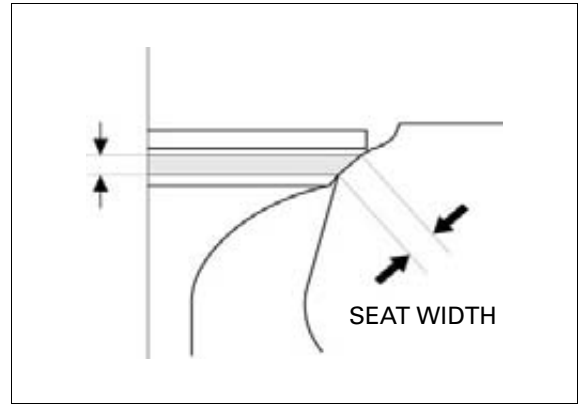

Inspect the valve seat face for:

- Uneven seat width:
 - Replace the valve and reface the valve seat.
- Damaged face:
 - Replace the valve and reface the valve seat.

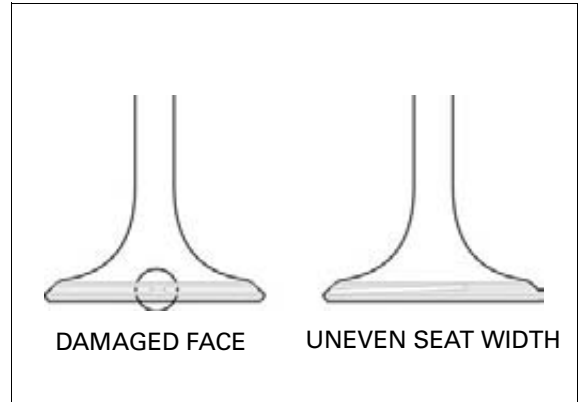

The valves cannot be ground. If a valve face is burned or badly worn or if it contacts the seat unevenly, replace the valve.

- Contact area (too high or too low)
 - Reface the valve seat.

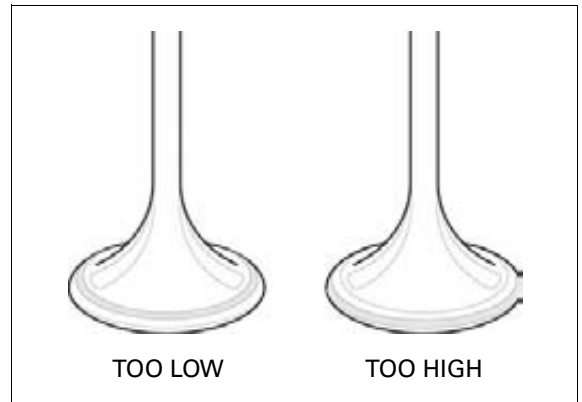

VALVE SEAT REFACING

Follow the refacing manufacturer's operating instructions.

Valve seat cutters/grinders or equivalent valve seat refacing equipment are recommended to correct worn valve seats.

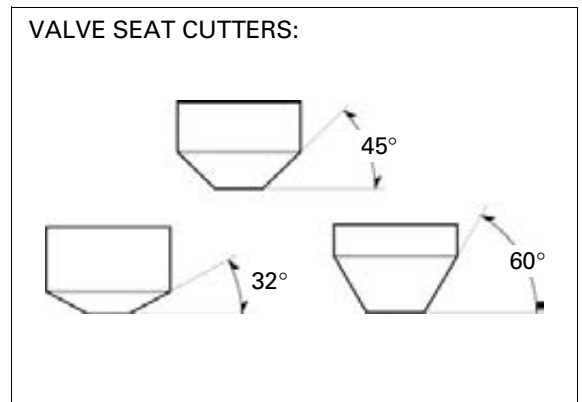

CYLINDER HEAD/VALVES

If the contact area is too high on the valve, the seat must be lowered using a 32-degree flat cutter.

If the contact area is too low on the valve, the seat must be raised using a 60-degree interior cutter.

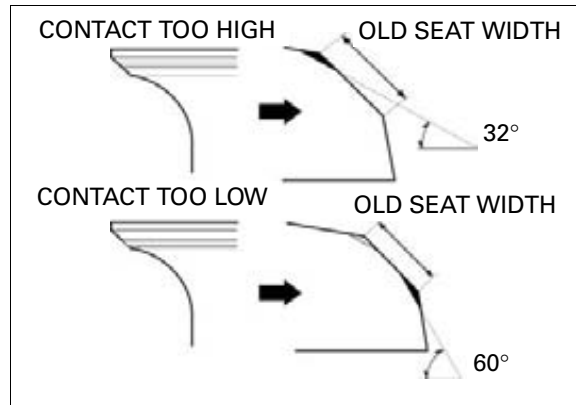

Reface the seat with a 45-degree cutter whenever a valve guide is replaced. Use a 45-degree cutter to remove any roughness or irregularities from the seat.

TOOLS:

Seat cutter, 29 mm (IN) 07780-0010300
Seat cutter, 24.5 mm (EX) 07780-0010100
Cutter holder, 4.5 mm 07781-0010600
or equivalent commercially available

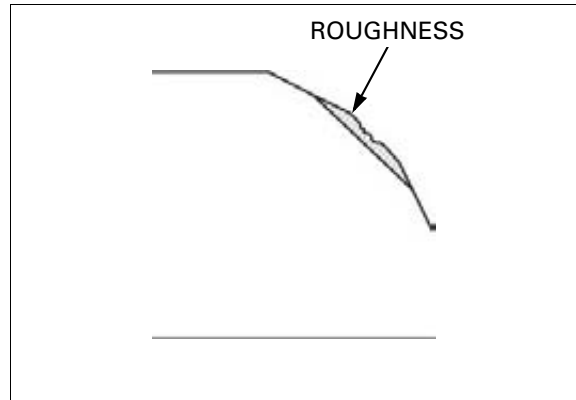

Use a 32-degree cutter to remove the top 1/4 of the existing valve seat material.

TOOLS:

Flat cutter, 30 mm (IN) 07780-0012200
Flat cutter, 27 mm (EX) 07780-0013300
Cutter holder 07781-0010600
or equivalent commercially available

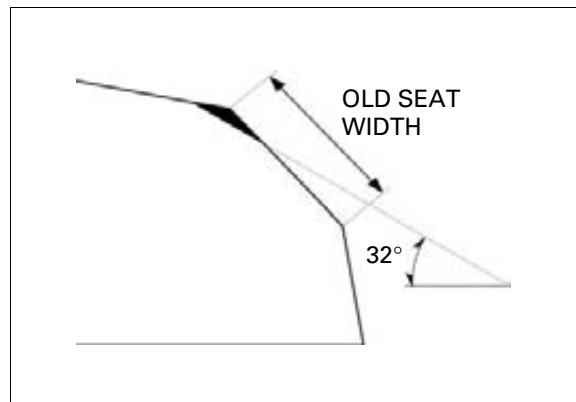

Use a 60-degree cutter to remove the bottom 1/4 of the old seat.

TOOLS:

Interior cutter, 30 mm (IN) 07780-0014000
Interior cutter, 26 mm (EX) 07780-0014500
Cutter holder 07781-0010600
or equivalent commercially available

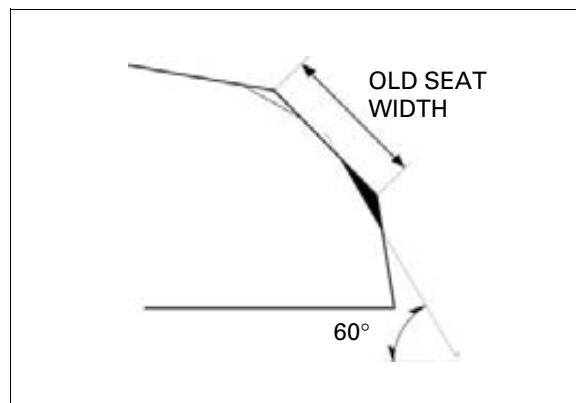

Using a 45-degree seat cutter, cut the seat to the proper width. Make sure that all pitting and irregularities are removed. Refinish if necessary.

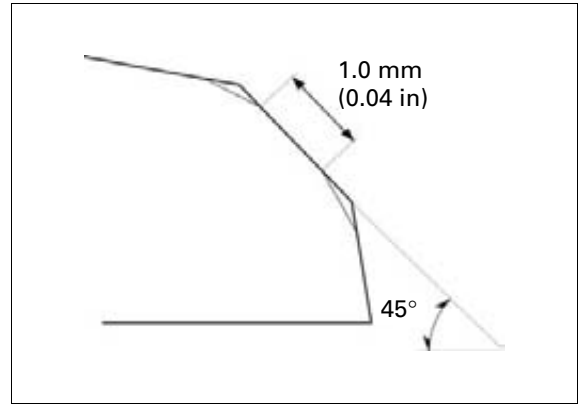

After cutting the seat, apply lapping compound to the valve face, and lap the valve using light pressure.

- Excessive lapping pressure may deform or damage the seat.
- Change the angle of lapping tool frequently to prevent uneven seat wear.
- Do not allow lapping compound to enter the guides.

After lapping, wash all residual compound off the cylinder head and valve.

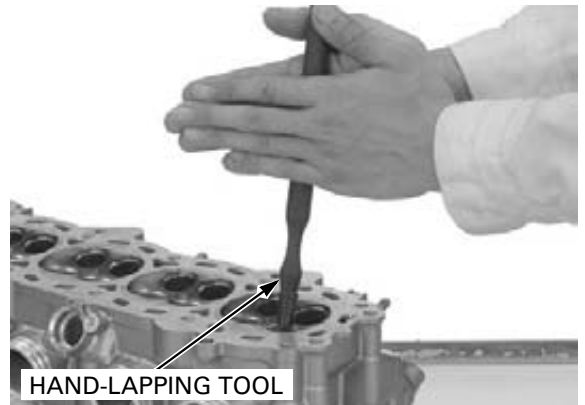

HAND-LAPPING TOOL

CYLINDER HEAD ASSEMBLY

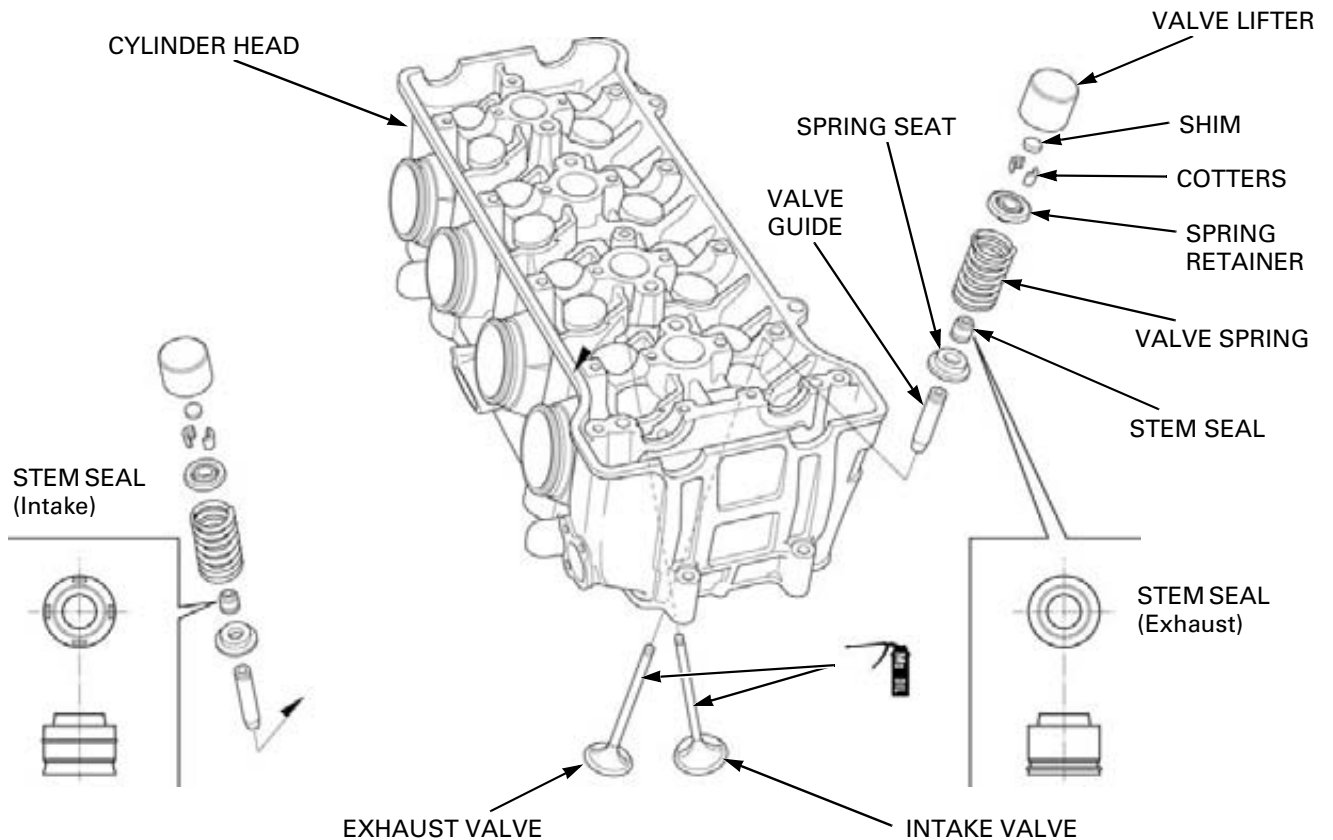

CYLINDER HEAD/VALVES

Blow through all oil passages in the cylinder head with compressed air.

Install the tappet hole protector into the valve lifter bore.

TOOL:

Tappet hole protector

07HMG-MR70002 or refer to page 9-14 for alternative tool

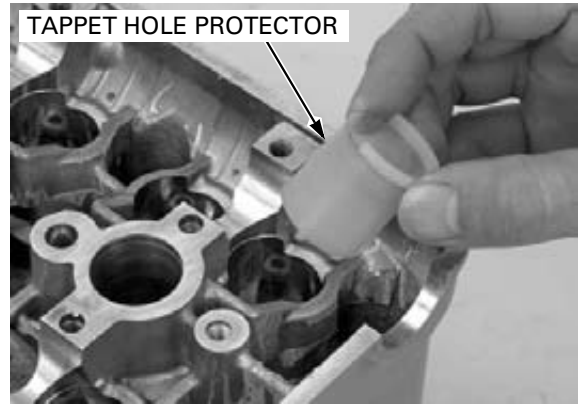

Install the valve spring seats.

Install the new stem seals.

Lubricate the valve stems with molybdenum oil solution.

Insert the valve into the valve guide while turning it slowly to avoid damage to the stem seal.

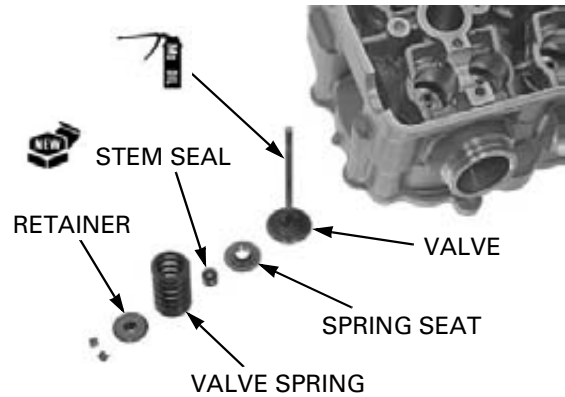

Install the valve springs with the tightly wound coils facing the combustion chamber.

Install the valve spring retainer.



COMBUSTION CHAMBER SIDE

Grease the cotters to ease installation.

Install the valve cotters using the special tools as shown.

NOTE:

To prevent loss of tension, do not compress the valve spring more than necessary.

TOOLS:

Valve spring compressor

07757-0010000

Valve spring compressor attachment

07959-KM30101

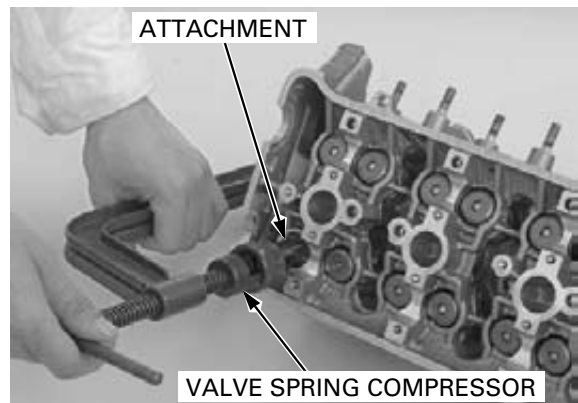

CYLINDER HEAD/VALVES

Support the cylinder head above the work bench surface to prevent possible valve damage.

Tap the valve stems gently with two plastic hammers as shown to seat the cotters firmly.

Install and tighten the spark plugs.

TORQUE: 16 N·m (1.6 kgf·m, 12 lbf·ft)

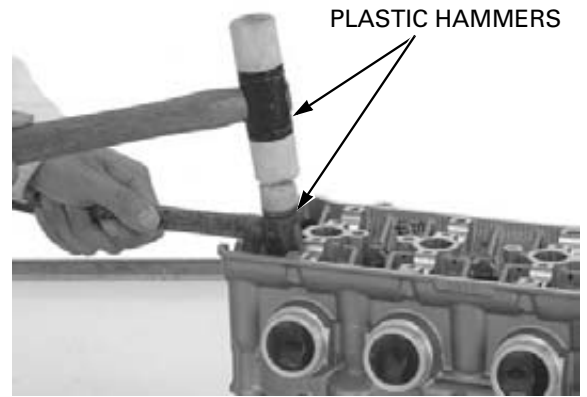

Install the new O-ring onto the water hose joint. Install the water hose joint to the cylinder head and tighten the bolt securely.

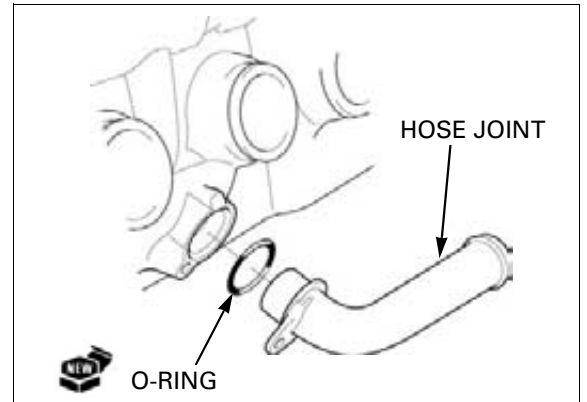

CYLINDER HEAD INSTALLATION

Install the timing sprocket by aligning the wide teeth between the crankshaft and timing sprocket.

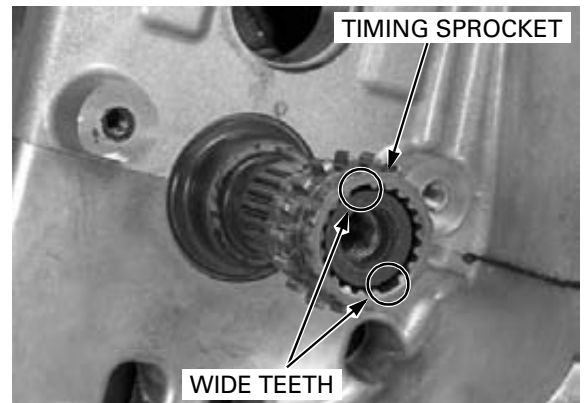

Install the cam chain.

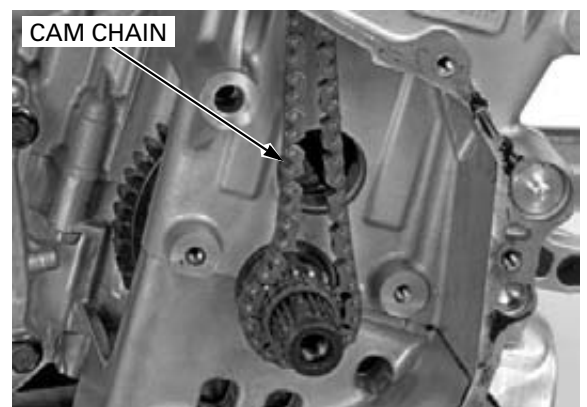

CYLINDER HEAD/VALVES

Apply a locking agent to the cam chain guide torx bolt threads.
Install the pivot collar, cam chain guide, washer and torx bolt.

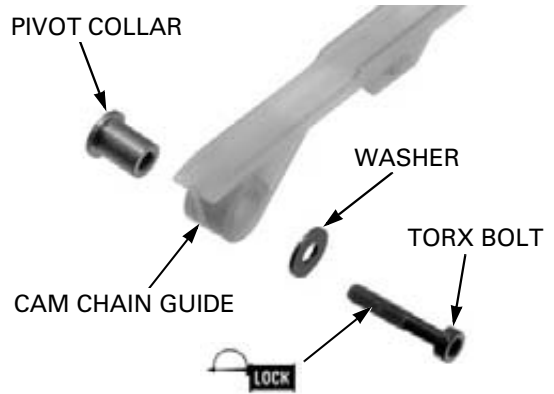

Apply a locking agent to the cam chain tensioner socket bolt threads.
Install the washer, cam chain tensioner and socket bolt.

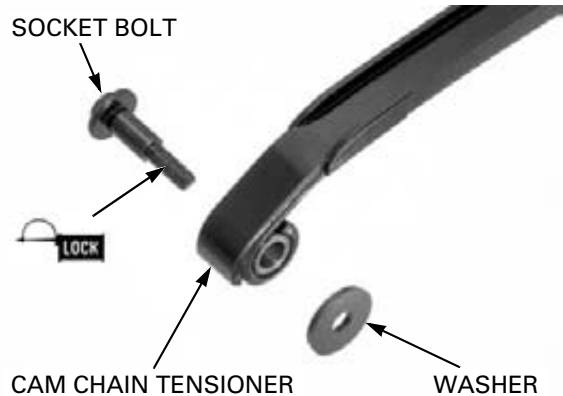

Tighten the cam chain guide torx bolt to the specified torque.

TORQUE: 12 N·m (1.2 kgf·m, 9 lbf·ft)

Tighten the cam chain tensioner socket bolt to the specified torque.

TORQUE: 10 N·m (1.0 kgf·m, 7 lbf·ft)

Install the following:

- Starter clutch (page 10-32)
- Right crankcase cover (page 10-33)

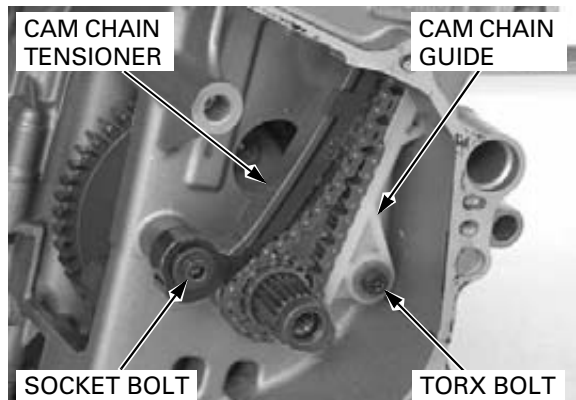

Install the dowel pins and a new cylinder head gasket as shown.

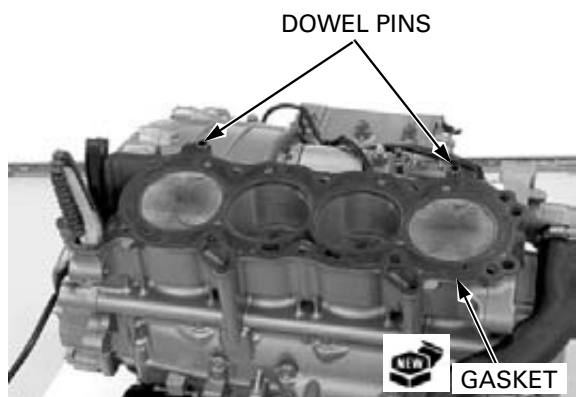

Apply molybdenum disulfide oil solution to the threads and seating surface of the 9 mm bolts/washers and install them.

Install the two 6 mm flange bolts.

Tighten the 9 mm bolts in a crisscross pattern in two or three steps to the specified torque.

TORQUE: 51 N·m (5.2 kgf·m, 38 lbf·ft)

Tighten the 6 mm flange bolts.

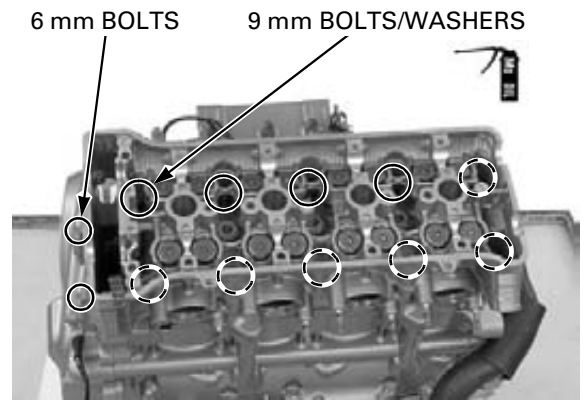

Retract the cam chain tensioner lifter shaft and secure it using the cam chain tensioner holder.

TOOL:

Cam chain tensioner holder 07ZMG-MCAA400

Point the gasket tab as shown.

Install a new gasket onto the cam chain tensioner lifter.

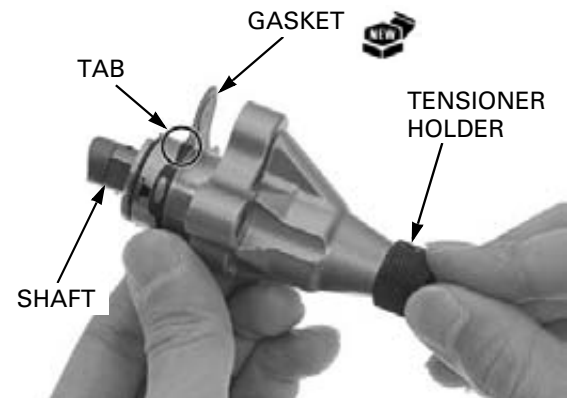

Make sure the gasket tab is in the direction as shown.

Install the cam chain tensioner lifter onto the cylinder head with new gasket.

Install the mounting bolts with the new sealing washers.

Tighten the mounting bolts securely.

Install the engine into the frame (page 8-8).

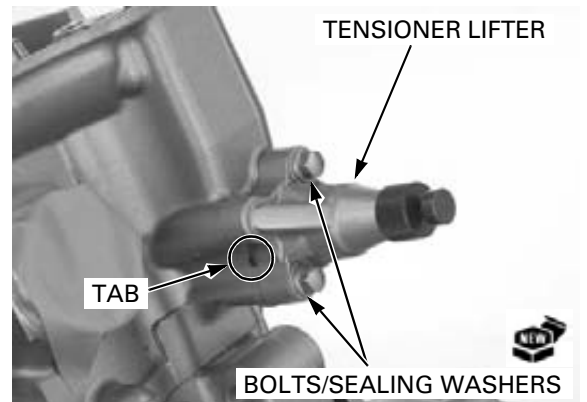

CAMSHAFT INSTALLATION

Apply molybdenum oil solution to the outer surface of the each valve lifter.

Install the shims and valve lifters in their original locations.

Install the shims on the retainers and valve lifters into the valve lifter bores.

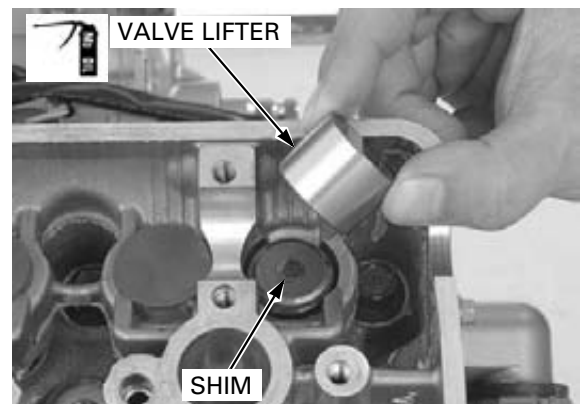

CYLINDER HEAD/VALVES

The each camshaft has identification mark.

- IN: Intake camshaft
- EX: Exhaust camshaft

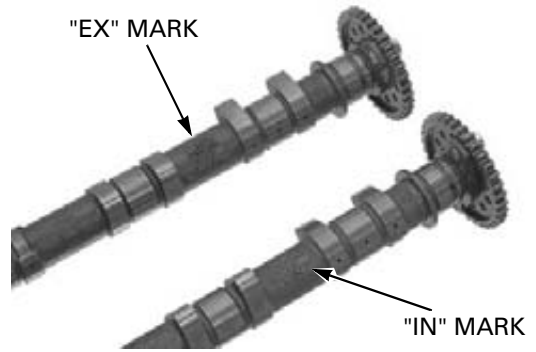

If the cam sprockets are removed, install the cam sprockets onto the camshafts.

- Install the intake cam sprocket with the timing mark (IN) facing outward and the No.1 cam lobes facing up and out as shown.
- Install the exhaust cam sprocket with the timing mark (EX) facing outward and the No.1 cam lobes facing up and out as shown.

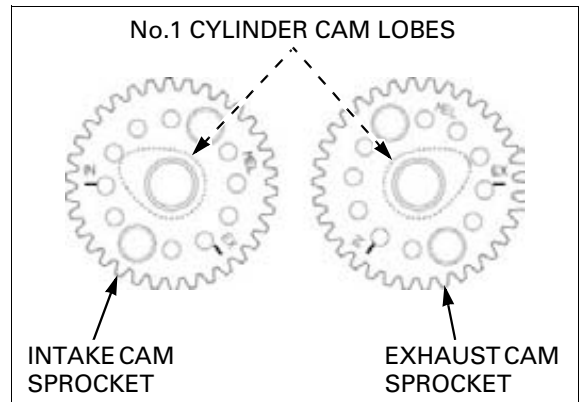

Clean the cam sprocket bolt threads and apply a locking agent.
Install the cam sprockets and bolts.

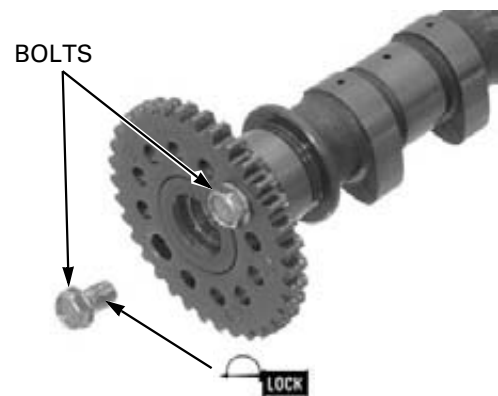

Turn the crankshaft clockwise and align the "T" mark on the starter clutch outer with the index notch on the right crankcase cover.

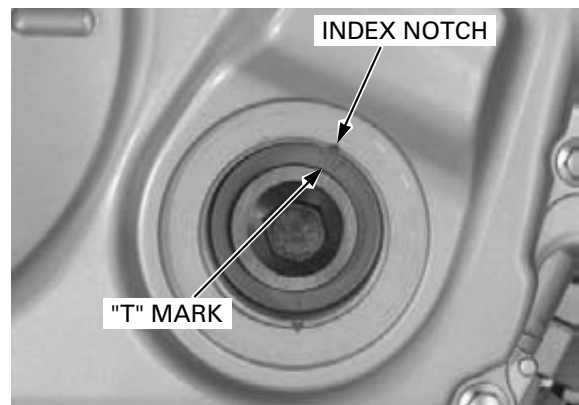

CYLINDER HEAD/VALVES

Apply molybdenum oil solution to the camshaft journal of the cylinder head.

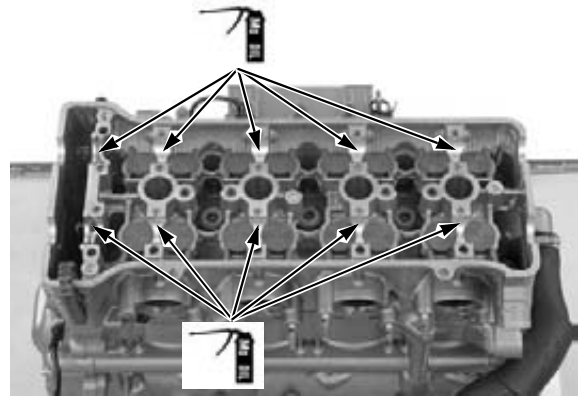

Install the cam chain over the cam sprockets and then install the intake and exhaust camshafts.

- Install each camshaft to the correct locations with the identification marks.
"IN": Intake camshaft
"EX": Exhaust camshaft

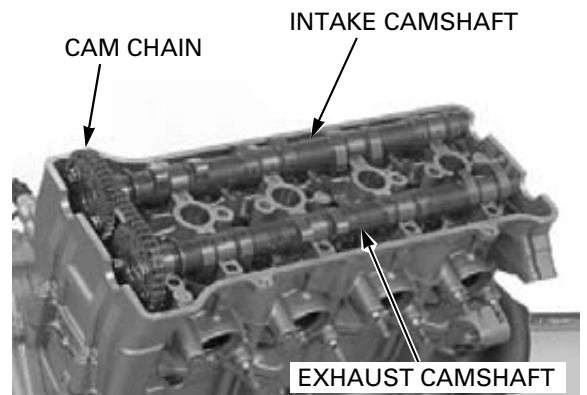

- Make sure that the timing marks on the cam sprockets are facing outward and flush with the cylinder head upper surface as shown.

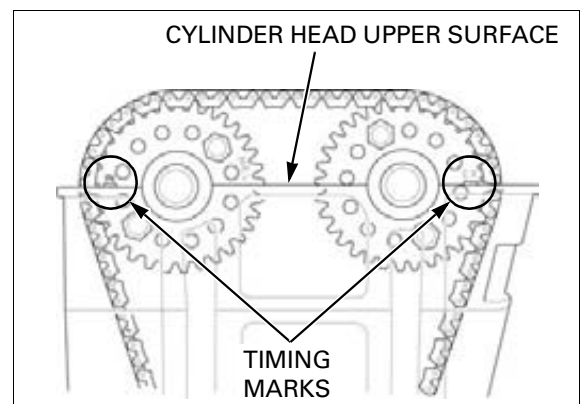

Coat new O-rings with clean engine oil and install them into the grooves in the camshaft holders.

Apply molybdenum oil solution to the camshaft journals of the camshaft holders.

Install each camshaft holder onto the camshafts.

Be sure to align the dowel pins in the camshaft holder with the holes in the cylinder head.

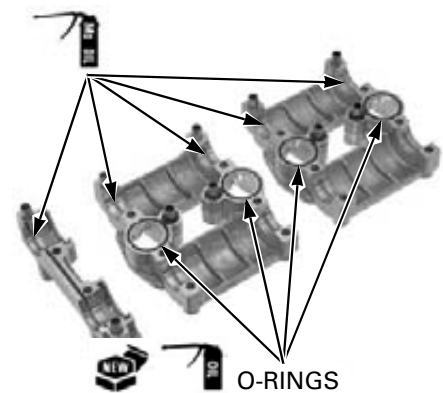

CYLINDER HEAD/VALVES

Note the correct locations with the identification marks as shown.

- No mark: right camshaft holder
- "R" mark: center camshaft holder
- "L" mark: left camshaft holder

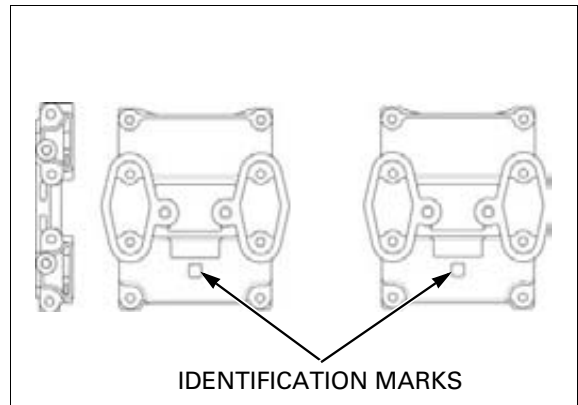

Apply engine oil to the threads and seating surfaces of the camshaft holder bolts. Install the twenty holder bolts with new eight sealing washers as shown.

Finger tighten the bolts.

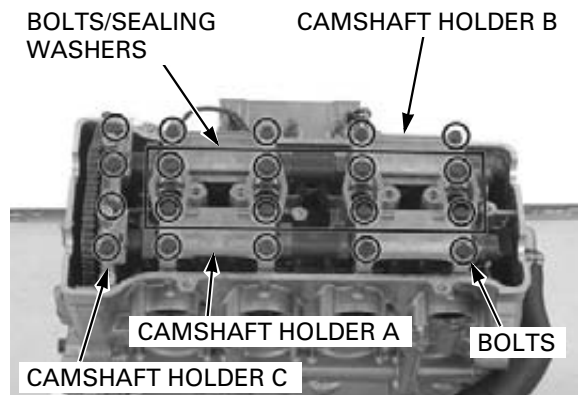

First gradually tighten the four bolts (No.1 – No.2 – No.7 – No.8) in the numerical order cast on the camshaft holders.

Gradually tighten the other camshaft holder bolts until the camshaft holders lightly contact the cylinder head surface.

NOTICE

Failure to tighten the camshaft holder in a crisscross pattern might cause a camshaft holder to break.

Tighten all camshaft holder bolts in the numerical order cast on the camshaft holders.

TORQUE: 12 N·m (1.2 kgf·m, 9 lbf·ft)

In case the cam sprockets were removed, apply a locking agent to the cam sprocket bolt threads. Tighten the cam sprocket bolts to the specified torque.

TORQUE: 20 N·m (2.0 kgf·m, 15 lbf·ft)

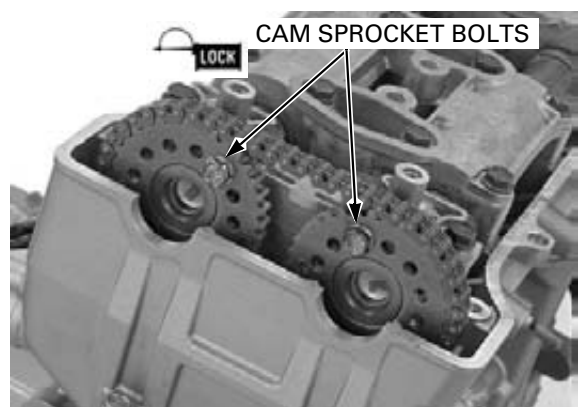
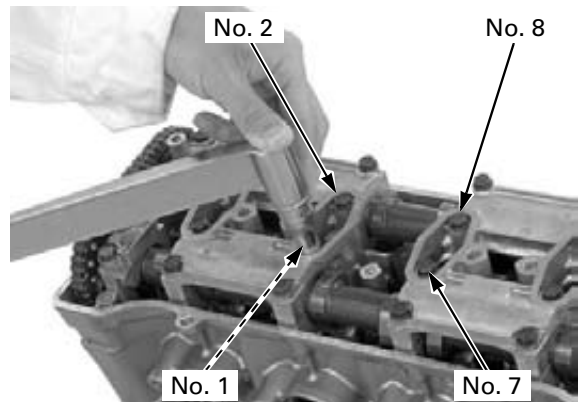

CYLINDER HEAD/VALVES

Turn the crankshaft clockwise one full turn (360°) and tighten the other cam sprocket bolts.

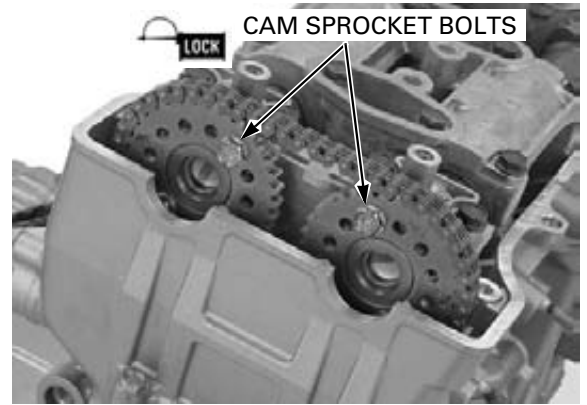

Install the cam chain guide B, and tighten the bolts.

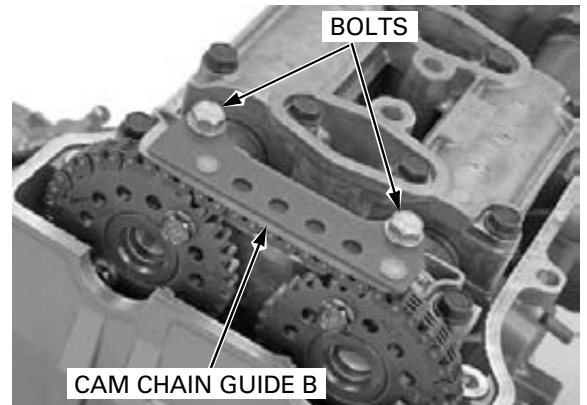

Remove the special tool from the cam chain tensioner lifter.

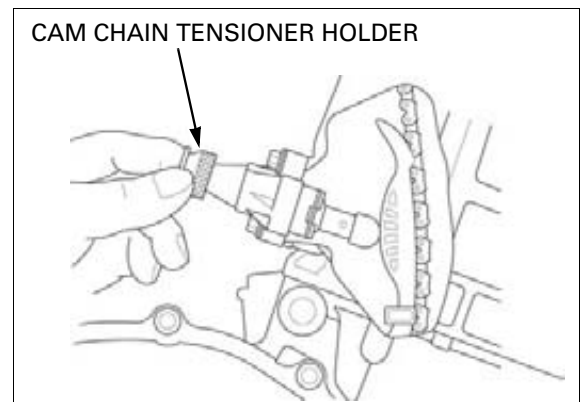

Install a new sealing washer and tighten the sealing bolt.

Recheck the valve timing.

Install the cylinder head cover (page 9-31).

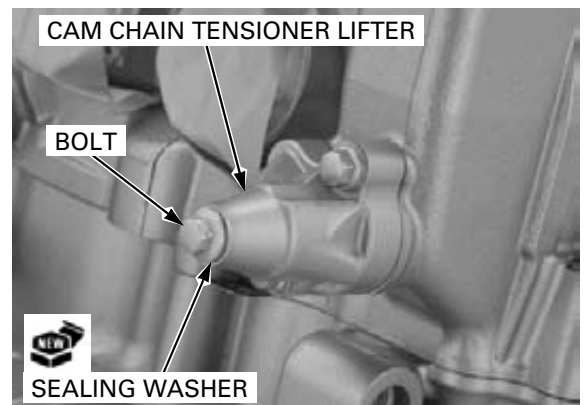

CYLINDER HEAD/VALVES

CYLINDER HEAD COVER ASSEMBLY

Install the PAIR check valve port plates into the cylinder head cover.

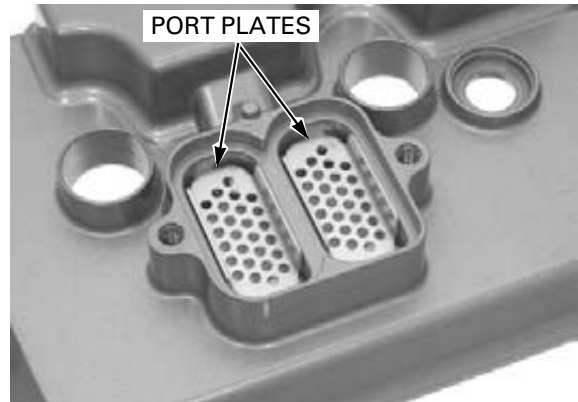

Install the PAIR check valves into the cylinder head cover.

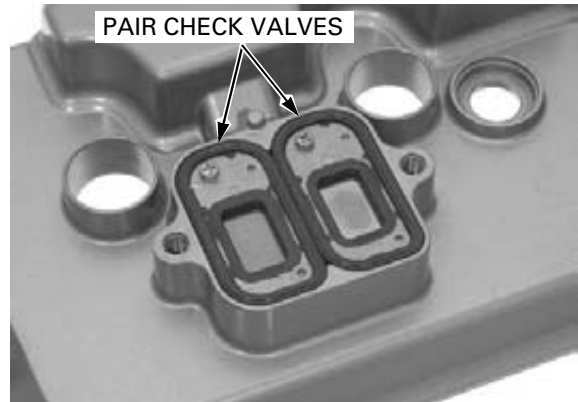

Apply a locking agent to the PAIR check valve cover mounting bolt threads.

Install the PAIR check valve cover and tighten the bolts to the specified torque.

TORQUE: 12 N·m (1.2 kgf·m, 9 lbf·ft)

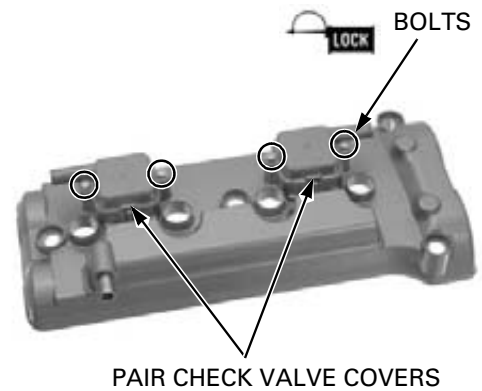

Install the new cylinder head cover packing into the cylinder head cover grooves.

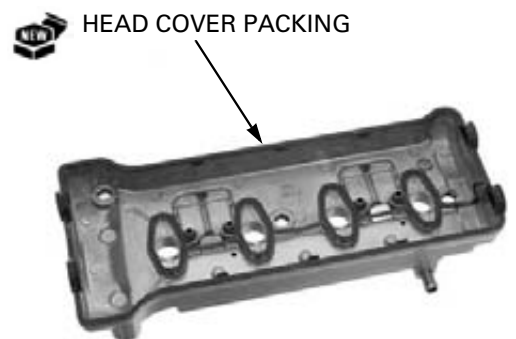

CYLINDER HEAD COVER INSTALLATION

Apply sealant to the cylinder head semi-circular cut-outs as shown.

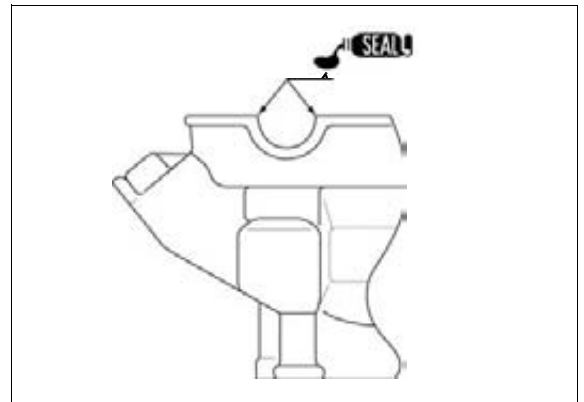

Install the cylinder head cover onto the cylinder head.

Install the washers to the cylinder head cover with their "UP" mark facing up.

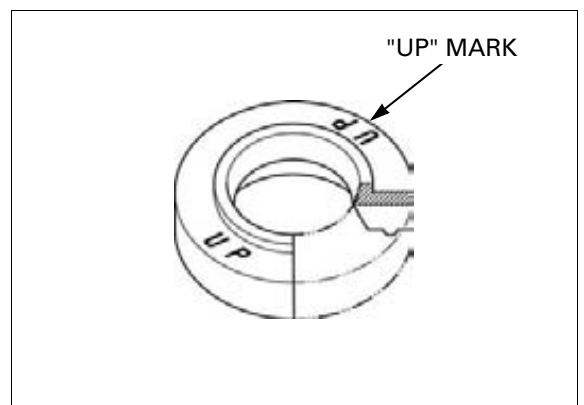

Install and tighten the cylinder head cover bolts to the specified torque.

TORQUE: 10 N·m (1.0 kgf·m, 7 lbf·ft)

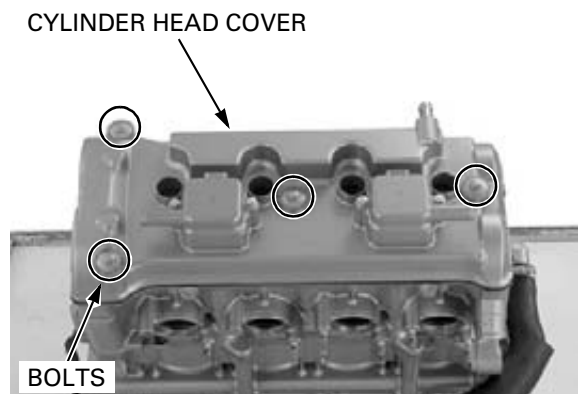

Connect the crankcase breather hose to the cylinder head cover.

Install the PAIR control solenoid valve and connect the air hoses (page 6-85).

Connect the spark plug caps (page 4-10).

Install the fuel tank (page 6-59).

If the cylinder head was removed, perform as follows:

- Fill and bleed the cooling system (page 7-6)
- Fill the crankcase with engine oil (page 4-16)

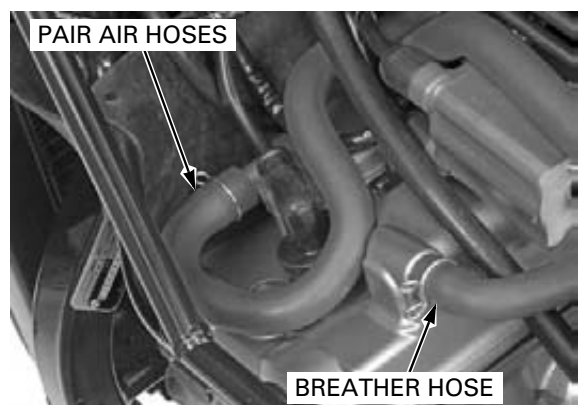

MEMO
