

# 21. Lights/Meters/Switches

<b>Service Information</b>	<b>21-1</b>	<b>Bank Angle Sensor</b>	<b>21-5</b>
<b>System Location</b>	<b>21-2</b>	<b>Fuel Cut-off Relay</b>	<b>21-5</b>
<b>Headlight</b>	<b>21-3</b>	<b>Fuel Pump Inspection</b>	<b>21-6</b>
<b>Front Turn Signal</b>	<b>21-3</b>	<b>Fuel light Test Circuit Inspection</b>	<b>21-6</b>
<b>Rear Turn Signal and Brake/Taillight</b>	<b>21-3</b>	<b>Fuel Pump Removal/Installation</b>	<b>21-7</b>
<b>Position Light</b>	<b>21-4</b>	<b>Combination Meter Removal/Installation</b>	<b>21-8</b>
<b>Indicator Bulb Replacement</b>	<b>21-4</b>	<b>Combination Meter Disassembly/Assembly</b>	<b>21-10</b>
<b>Side Stand Switch</b>	<b>21-4</b>		

## Service Information

### ⚠ WARNING

- A halogen headlight bulb becomes very hot while the headlight is ON, and remain hot for a while after it is turned OFF. Be sure to let it cool down before servicing.
- Use an electric heating element to heat the water/coolant mixture for the fan motor switch inspection. Keep all flammable materials away from the electric heating element. Wear protective clothing, insulated gloves and eye protection.
- Note the following when replacing the halogen headlight bulb.
  - Wear clean gloves while replacing the bulb. Do not put finger prints on the headlight bulb, as they may create hot spots on the bulb and cause it to fail.
  - If you touch the bulb with your bare hands, clean it with a cloth moistened with alcohol to prevent its early failure.
  - Be sure to install the dust cover after replacing the bulb.
- Check the battery condition before performing any inspection that requires proper battery voltage.
- A continuity test can be made with the switches installed on the motorcycle.  
For the following component locations, see page 21-2 of this manual (System Location); for inspections, refer to the applicable pages.

Component	Inspection method	Remarks
Clutch switch	Section 25 of the Common Service Manual	
Front brake light switch	Section 25 of the Common Service Manual	
Horn	Section 25 of the Common Service Manual	
Handlebar switches	Check for continuity on the continuity chart of the Wiring Diagram, section 22.	Switch connectors are located behind the instruments (page 1-25).
Ignition switch		
Neutral switch	Section 25 of the Common Service Manual	TORQUE: 12 N·m (1.2 kg-m, 9 ft-lb) Apply sealant to the threads.
Oil pressure switch/indicator light	Section 25 of the Common Service Manual	Oil pressure check: Section 4 of the Common Service Manual. Oil pressure switch torque: 12 N·m (1.2 kg-m, 9 ft-lb)
Fan motor switch	Section 25 of the Common Service Manual	
Rear brake light switch	Section 25 of the Common Service Manual	
Turn signal lights	Section 25 of the Common Service Manual	

# System Location

Standard model shown:

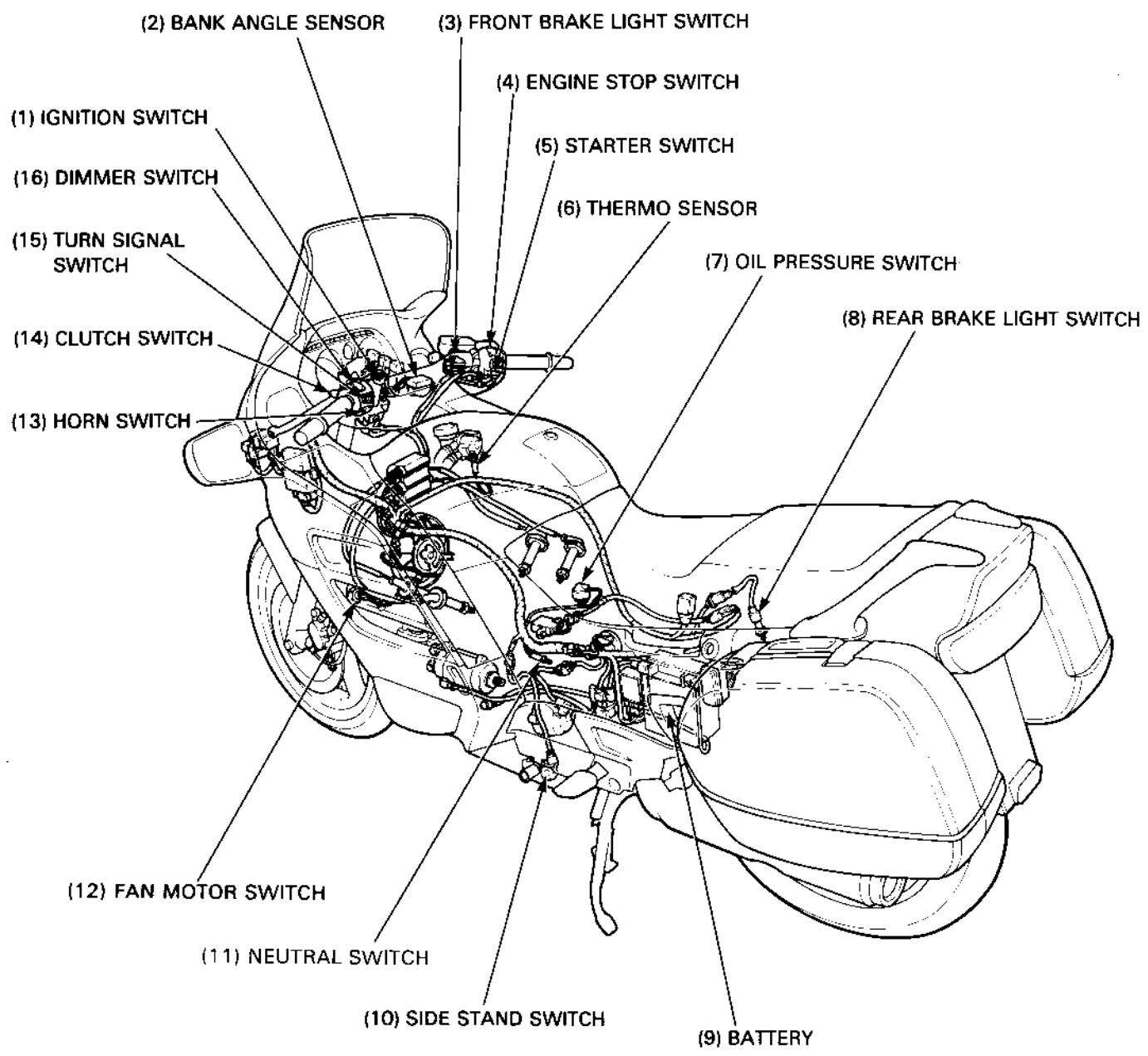

# Headlight

## Bulb Replacement

Remove the middle fairing inner cover (page 2-7).  
Disconnect the connector and remove the dust cover.  
Remove the bulb by removing the bulb retainer.  
Install a new headlight bulb.

### CAUTION

- If you touch the bulb with your bare hands, clean it with a cloth moistened with alcohol to prevent early failure.

### NOTE

- Install the dust cover with its "TOP" mark facing up.

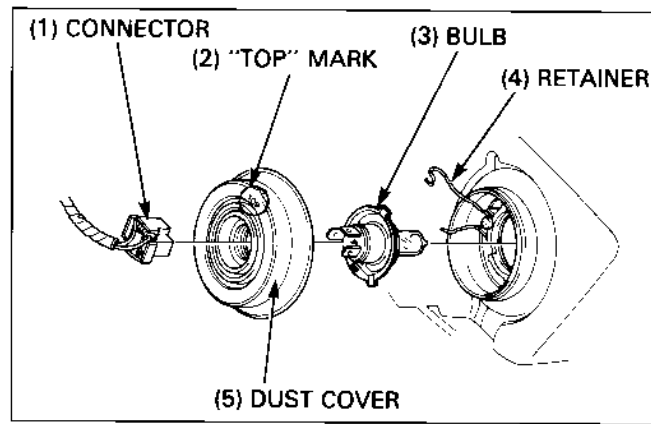

# Front Turn Signal

## Bulb Replacement

Remove the rear view mirror (page 2-8).  
Remove the bulb socket by turning it counterclockwise.  
Remove the bulb by turning it counterclockwise while pushing in the bulb.

### NOTE

- Check that the rubber seal is in good condition and replace it if necessary.

Installation is in the reverse order of removal.  
Install the rear view mirror (page 2-8).

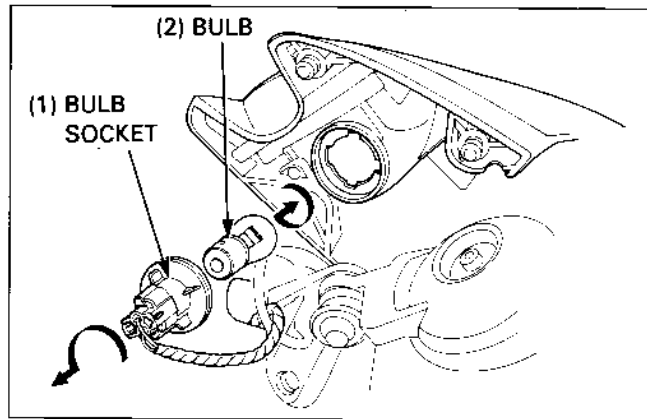

# Rear Turn Signal and Brake/ Taillight

## Bulb Replacement

Remove the seat (page 2-2).  
Fold the rear end shields as shown.

Remove the bulb socket by turning it counterclockwise.  
Remove the bulb by turning it counterclockwise while pushing in the bulb.

### NOTE

- Check that the rubber seal is in good condition and replace it if necessary.

Installation is in the reverse order of removal.  
Install the seat (page 2-2).

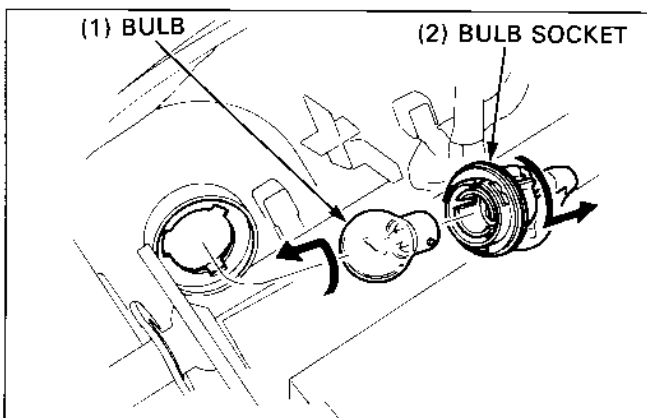
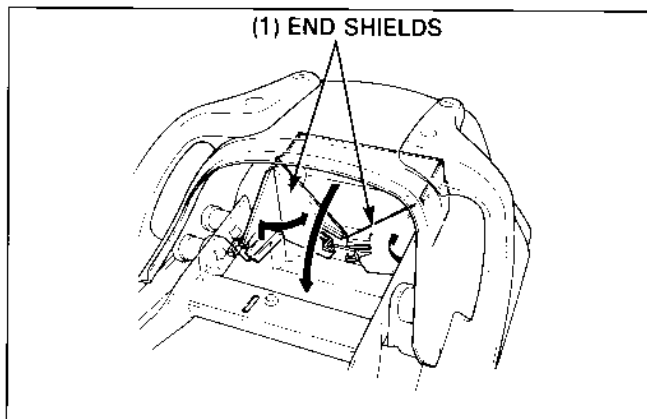

## Indicator Bulb Replacement

Remove the instrument panel (page 2-7).  
 Remove the bulb socket and bulb.  
 Install a new bulb and install the removed parts in the reverse order of removal.

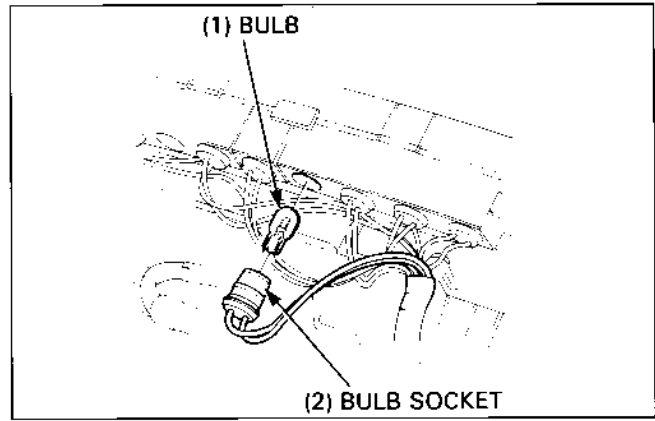

## Side Stand Switch

### Inspection

Remove the left side cover (page 2-2).  
 Disconnect the side stand 3P connector (green) and check for continuity between each terminal as shown below.  
 There should be continuity between the ○—○ positions on the continuity chart.

	Green/ White	Yellow/ Black	Green
Side stand down		○	○
Side stand up	○		○

Replace the side stand switch if Continuity is not as shown in the chart above.

### Replacement

Remove the pivot cover (page 2-5).  
 Disconnect the 3P connector (green) and release the wire from the clamp.  
 Remove the bolt and side stand switch.  
 Install the side stand switch aligning the stop pin on the frame with the cut out of the switch and the pin on the switch with the hole in the side stand.  
 Secure the side stand switch with the bolt.

**Torque: 10 N·m (1.0 kg-m, 7 ft-lb)**  
 Install removed parts in the reverse order of removal.

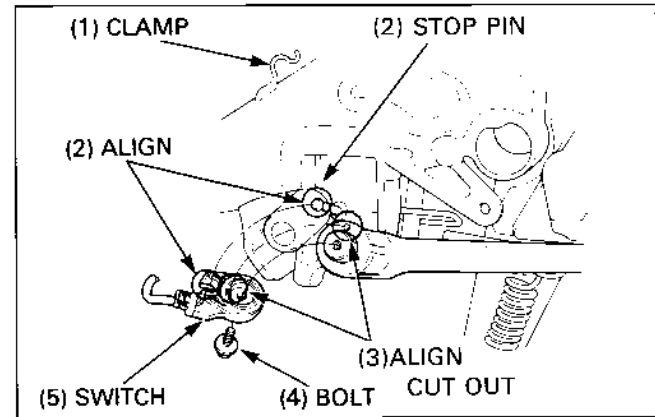
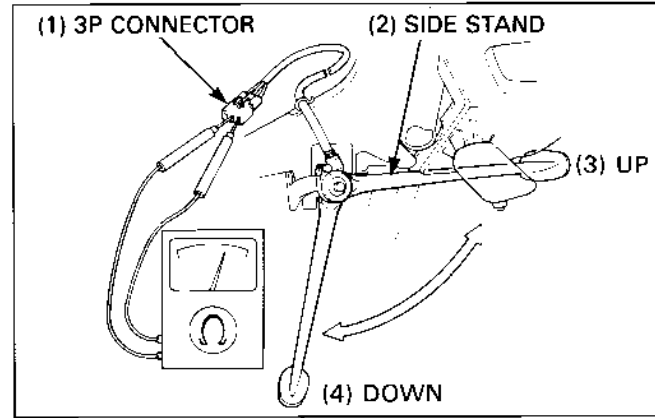

# Bank Angle Sensor

## Inspection

Remove the upper fairing (page 2-9).  
Turn the ignition switch "ON" and measure voltage between the following terminals of the bank angle sensor with the 3P connector (green) connected.

Terminals	Standard voltage
Red/White (+) and Green (-)	0-3.0V
White (+) and Green (-)	10.0-14.0V

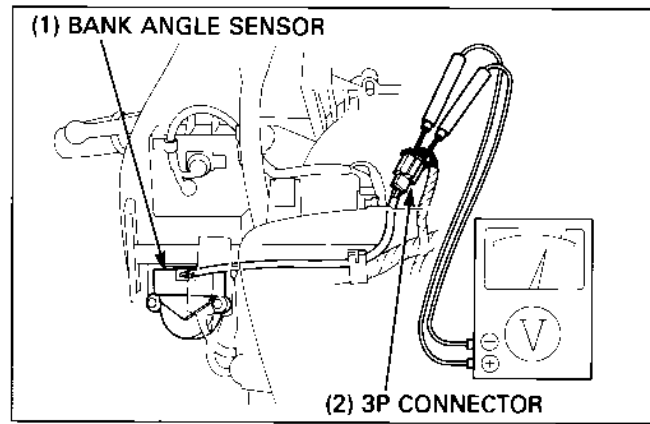

Remove the screws and bank angle sensor.  
Turn the ignition switch "OFF".  
Place the bank angle sensor horizontal with the connector connected and turn the ignition switch "ON".  
The bank angle sensor is normal if the bank angle sensor relay clicks and the power supply line is closed.  
Position the bank angle sensor at approximately 50 degrees to the left or right with the ignition switch "ON".  
The bank angle sensor is normal if the bank angle sensor relay clicks and the power supply line is open.

### NOTE

- If you repeat this test, first turn the ignition switch "OFF", then back to "ON" before you try the test again.

Installation is in the reverse order of removal.

# Fuel Cut-off Relay

### ⚠ WARNING

- Gasoline is extremely flammable and is explosive under certain conditions. Work in a well ventilated area.  
Do not smoke or allow flames or sparks in your work area or where gasoline is stored.

Remove the instrument panel (page 2-7).  
Check the sub fuse (10A:IGN, STARTER, ACG).  
Check the relay 4P connector (white) for looseness and corrosion.

Disconnect the relay connector and test the wires to the main harness side.

Item	Standard
Between the Bl/W (+) and body ground (-) with the ignition switch "ON".	Battery voltage should register
Bu/Y wire between the pump relay and fuel pump.	Continuity
Br/R wire between the fuel pump relay and fuel pump.	Continuity
Green wire and body ground	Continuity

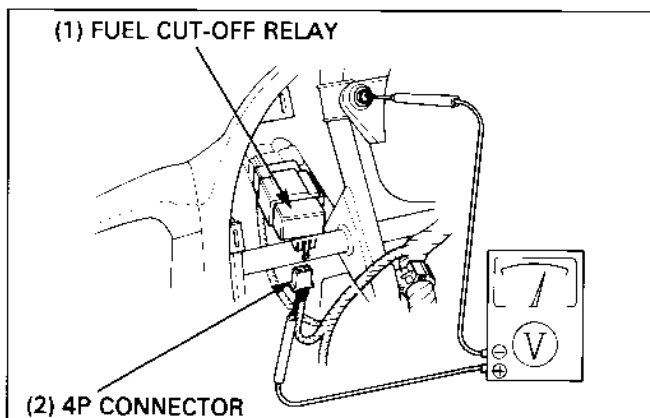
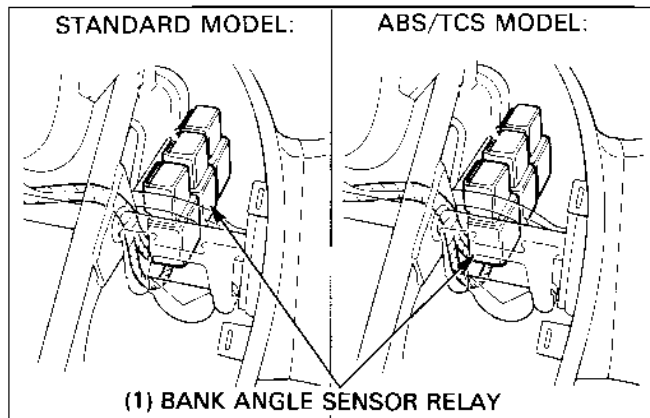
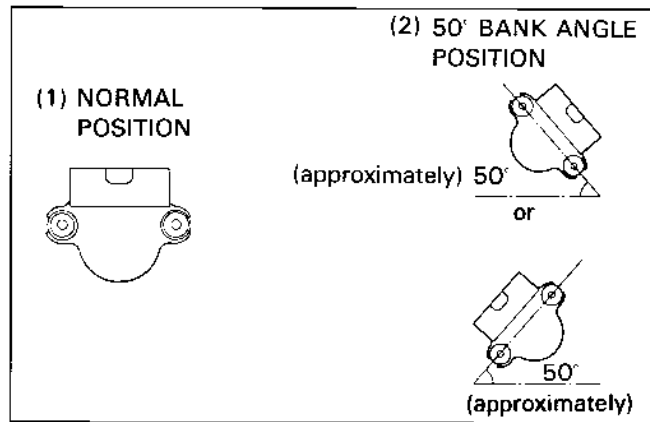

## Fuel Pump Inspection

Turn the ignition switch "OFF".  
 Remove the instrument panel (page 2-7).  
 Remove the seat (page 2-2).  
 Disconnect the fuel outlet tube at the fuel filter.

**⚠ WARNING**

- Gasoline is extremely flammable and is explosive under certain conditions. Work in a well ventilated area.  
 Do not smoke or allow flames or sparks in the your work area or where gasoline is stored.

Short the Black and Brown/Red wire terminals with a jumper wire.

Turn the ignition switch "ON" and let fuel flow into a graduated beaker for 5 seconds, then turn the ignition switch "OFF".

Multiply the amount in the beaker by 12 to determine the fuel pump flow capacity per minute.

Fuel pump flow minimum capacity:  
 640cc (0.676 U.S.qt, 0.563 Imp qt)/minute

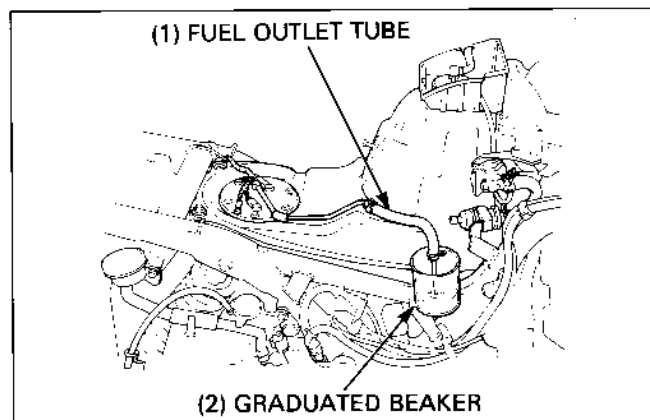
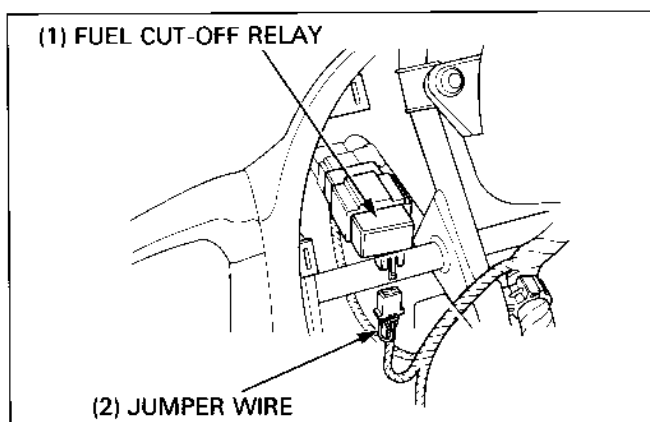

## Fuel Light Test Circuit Inspection

Turn the ignition switch "ON".  
 The fuel indicator light should come on for few seconds, then go off.  
 If it does not come on, check the fuel sensor circuit.

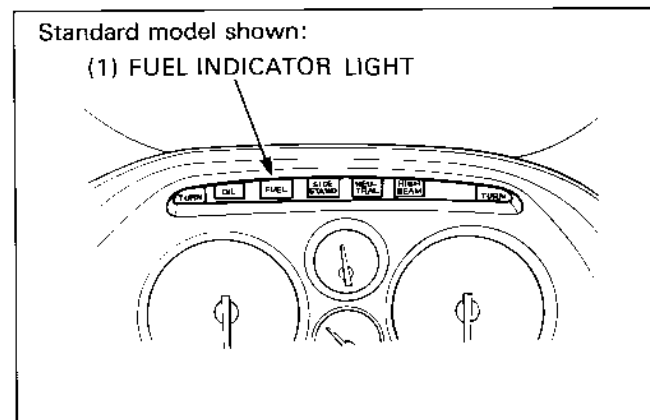

If there is no problem with the circuit, remove the upper fairing (page 2-9) and disconnect the indicator light check unit connector.

Measure the voltage between the Black/Brown and Green/Black wires of the connector at the wire harness side.

Battery voltage should be measured.  
 If battery voltage is measured, replace the check unit.  
 If battery voltage is not measured, check the wire harness for an open, short circuit or loose connection.

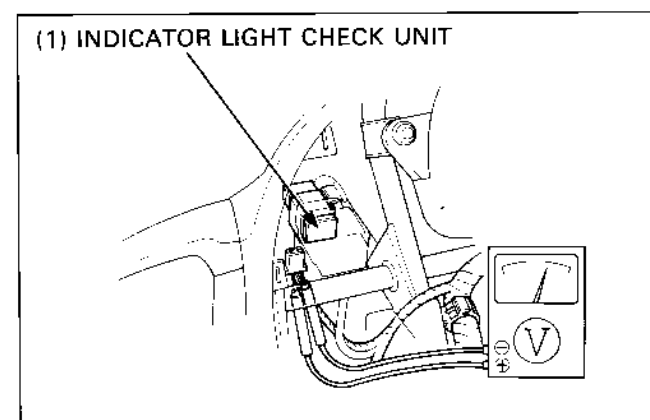

## Fuel Pump Removal/Installation

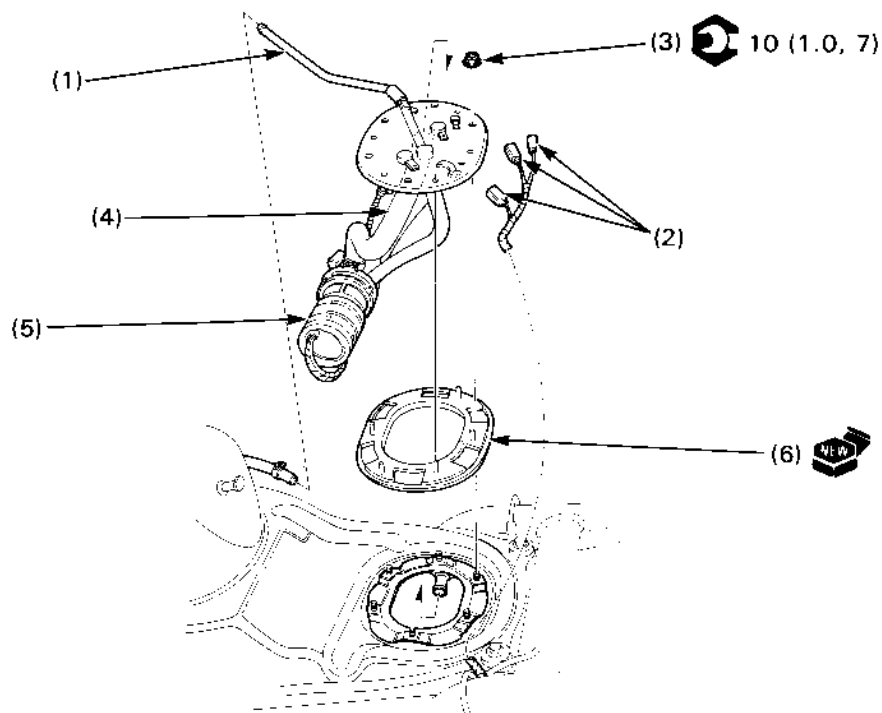

### ⚠ WARNING

- Gasoline is extremely flammable and is explosive under certain conditions. Refuel in a well-ventilated area with the engine stopped. Do not smoke or allow flames or sparks in your work area or where gasoline is stored.
- Keep away from flames or sparks. Wipe up spilled gasoline at once.

### Requisite Service

- Seat removal/installation (page 2-2)

Procedure	Q'ty	Remarks
<b>Removal Order</b>		Installation is in the reverse order of removal.
(1) Fuel outlet tube	1	
(2) Fuel pump/level sensor connector	3	
(3) Fuel pump mounting nut	6	
(4) Fuel inlet tube	1	
(5) Fuel pump assembly	1	
(6) Base packing	1	

# Combination Meter Removal/Installation

Standard Model

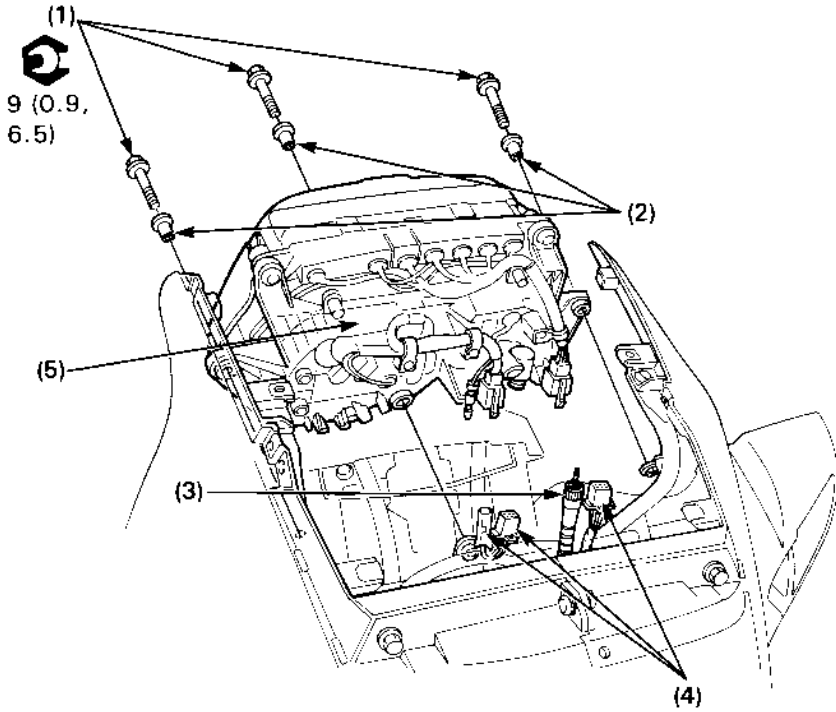

## Requisite Service

- Instrument panel removal/installation (page 2-7)

Procedure		Q'ty	Remarks
	<b>Removal Order</b>		Installation is in the reverse order of removal.
(1)	Meter mounting bolt	3	
(2)	Collar	3	
(3)	Speedometer cable	1	
(4)	Meter connector	3	
(5)	Meter assembly	1	



## ABS/TCS Model

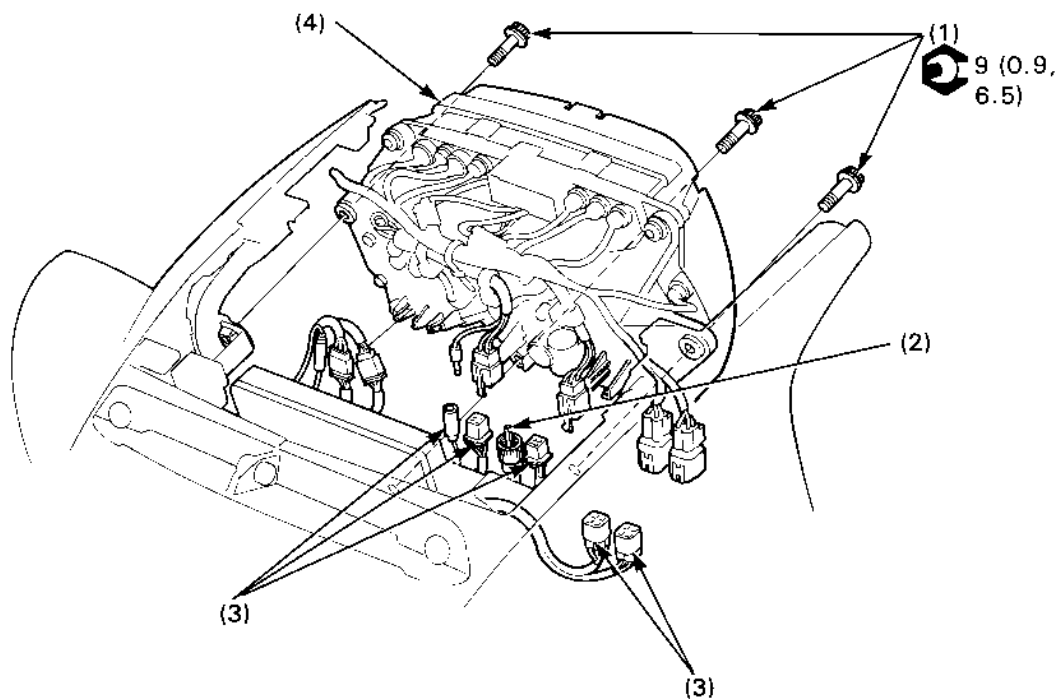

## Requisite Service

- Instrument panel removal/installation (page 2-7)

Procedure	Q'ty	Remarks
<b>Removal Order</b>		Installation is in the reverse order of removal.
(1) Meter mounting bolt	3	
(2) Speedometer cable	1	
(3) Meter connector	5	
(4) Meter assembly	1	

# Combination Meter Disassembly/Assembly

## Standard Model

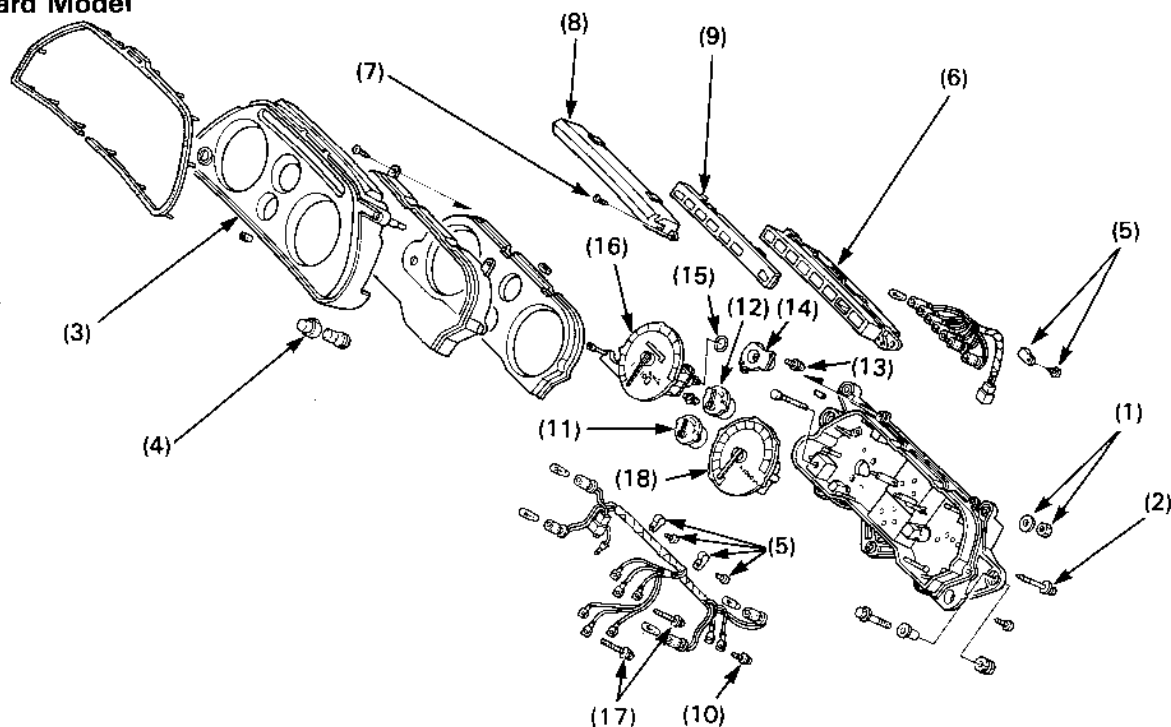

### Requisite Service

- Combination meter removal/installation (page 21-8)

Procedure	Q'ty	Remarks
<b>Disassembly Order</b>		Assembly is in the reverse order of disassembly.
(1) Nut/washer	2/2	
(2) Screw	5	
(3) Meter visor	1	
(4) Reset knob	1	
(5) Screw/Band	3/3	
(6) Indicator housing	1	
(7) Screw	2	
(8) Cover	1	
(9) Indicator lens	1	
(10) Terminal screw	6	
(11) Fuel gauge	1	
(12) Temperature gauge	1	
(13) Screw	4	
(14) Speedometer gear box	1	
(15) O-ring	1	
(16) Speedometer	1	
(17) Screw	2	
(18) Tachometer	1	

**ABS/TCS Model**

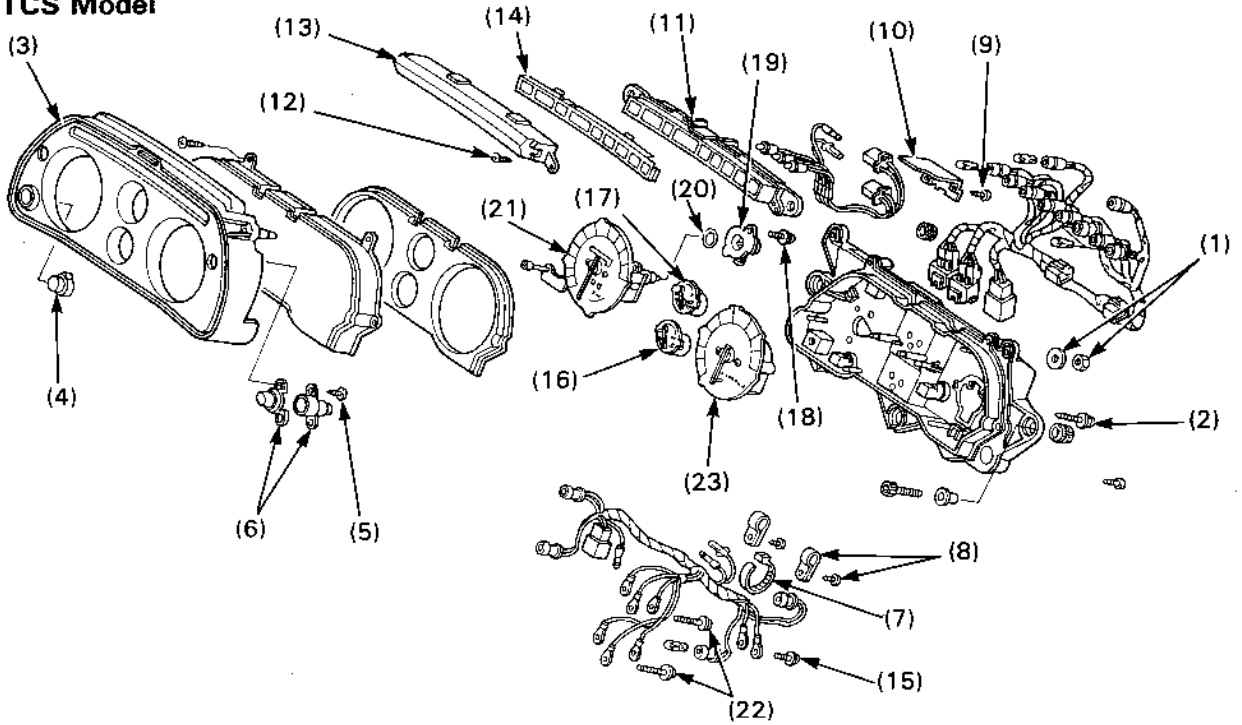















**Requisite Service**

- Combination meter removal/installation (page 21-9)

Procedure	Q'ty	Remarks
<b>Disassembly Order</b>		Assembly is in the reverse order of disassembly.
(1) Nut/washer	2/2	
(2) Screw	5	
(3) Meter visor	1	
(4) Reset knob	1	
(5) Screw	4	
(6) Lens/case	1/1	
(7) Harness band	1	
(8) Screw/band	2/2	
(9) Screw	2	
(10) Cover	1	
(11) Indicator housing	1	
(12) Screw	2	
(13) Cover	1	
(14) Indicator lens	1	
(15) Terminal screw	6	
(16) Fuel gauge	1	
(17) Temperature gauge	1	
(18) Screw	4	
(19) Speedometer gear box	1	
(20) O-ring	1	
(21) Speedometer	1	
(22) Screw	2	
(23) Tachometer	1	

# Symbols

The symbols used throughout this manual show specific service procedures. If supplementary information is required pertaining to these symbols, it would be explained specifically in the text without the use of the symbols.

	<p>Replace the part(s) with new one(s) before assembly.</p>
	<p>Use special tool</p>
	<p>Use optional tool. Use the same procedure you use to order parts.</p>
 <p>10 (1.0, 7.2)</p>	<p>Torque specification.    10 N·m (1.0 kg-m, 7.2 ft-lb)</p>
	<p>Use recommended engine oil, unless otherwise specified.</p>
	<p>Use molybdenum oil solution (mixture of the engine oil and molybdenum grease in a ratio of 1 : 1).</p>
	<p>Use multi-purpose grease (Lithium based multi-purpose grease NLGI #2 or equivalent)</p>
	<p>Use molybdenum disulfide grease (containing more than 3% molybdenum disulfide, NLGI #2 or equivalent)          Example: Molykote® BR-2 plus manufactured by Dow Corning, U.S.A.          Multi-purpose M-2 manufactured by Mitsubishi Oil Japan</p>
	<p>Use molybdenum disulfide paste (containing more than 40% molybdenum disulfide, NLGI #2 or equivalent)          Example: Molykote® G-n Paste manufactured by Dow Corning, U.S.A.          Honda Moly 60 (U.S.A. only)          Rocol ASP manufactured by Rocol Limited, U.K.          Rocol Paste manufactured by Sumico Lubricant, Japan</p>
	<p>Use silicone grease</p>
	<p>Apply a locking agent. Use a middle strength locking agent unless otherwise specified.</p>
	<p>Apply sealant</p>
	<p>Use brake fluid, DOT 3 or DOT 4. Use the recommended brake fluid, unless otherwise specified.</p>
	<p>Use Fork or Suspension Fluid.</p>