

# 3. Maintenance

<b>Service Information</b>	<b>3-1</b>	<b>Carburetor Synchronization</b>	<b>3-9</b>
<b>Service Access Guide</b>	<b>3-2</b>	<b>Engine Idle Speed</b>	<b>3-11</b>
<b>Maintenance Schedule</b>	<b>3-4</b>	<b>Radiator Coolant</b>	<b>3-11</b>
<b>Air Cleaner</b>	<b>3-6</b>	<b>Timing Belt</b>	<b>3-12</b>
<b>Spark Plugs</b>	<b>3-6</b>	<b>Brake Fluid</b>	<b>3-12</b>
<b>Valve Clearance</b>	<b>3-6</b>	<b>Brake System (LBS-ABS/TCS model)</b>	<b>3-13</b>
<b>Engine Oil</b>	<b>3-8</b>	<b>Headlight Aim</b>	<b>3-14</b>

## Service Information

- Refer to Common Service Manual for service procedures on items not included in this manual.
- Refer to specifications (Section 1) for maintenance service data.

# Service Access Guide

- The following shows the locations of the parts that must be removed for the maintenance items listed below. Refer to the Common Service Manual for items not included in this manual.
- Refer to section 2 (frame/body panels/exhaust system), for the parts that must be removed for service.  
For example: AIR CLEANER (Contamination, clogging, replacement) — Maintenance part (service items)
  - Top shelter — The parts that must be removed for service.

ABS/TCS model shown:

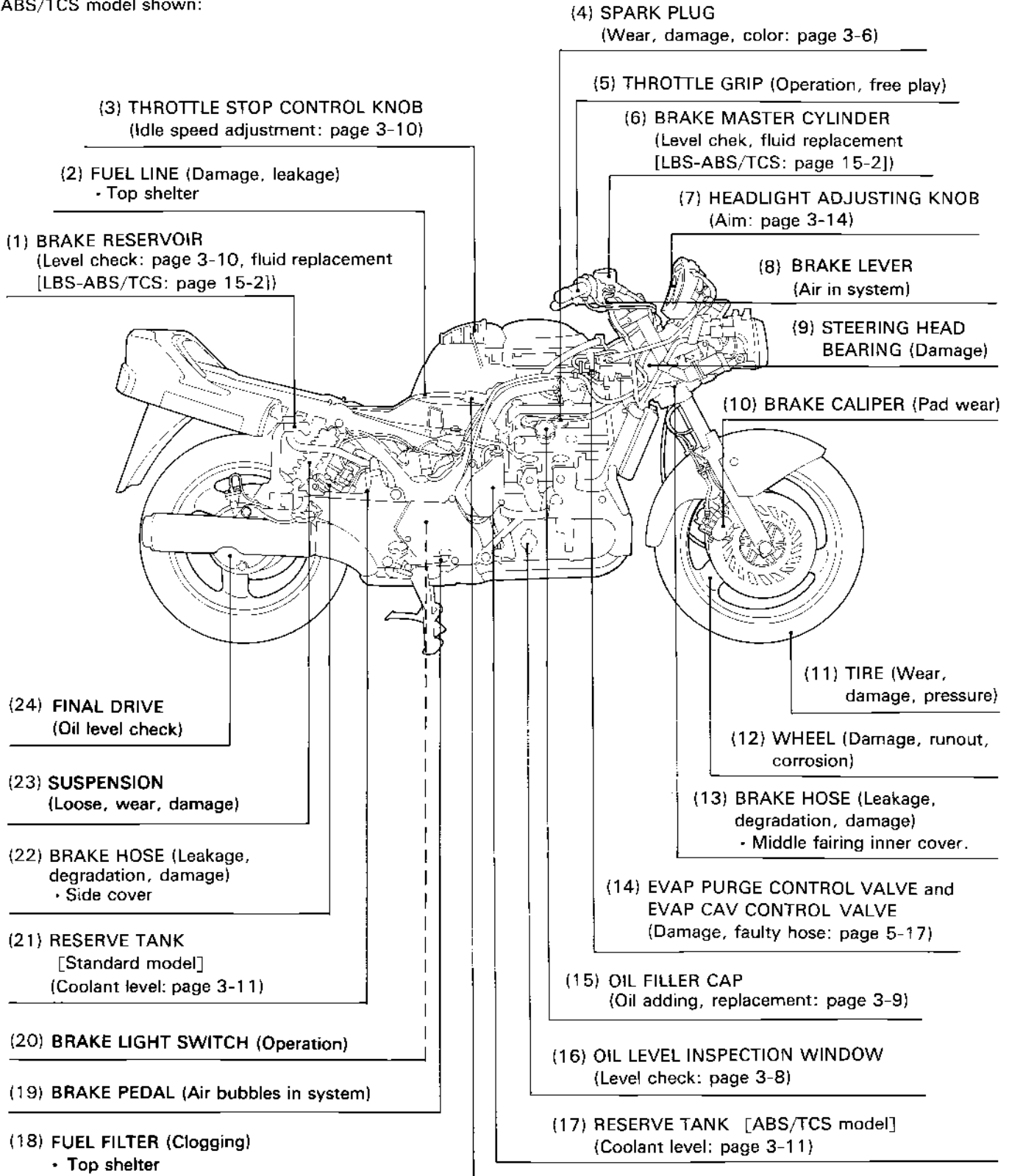

ABS/TCS model shown:

(6) PAIR CONTROL VALVE  
(Damage, faulty hose: page 5-17)

(5) CARBURETOR CHOKE (Operation)

(4) CLUTCH MASTER CYLINDER  
(Level check, fluid replacement)

(3) CLUTCH LEVER  
(Air in system)

(2) HEADLIGHT  
ADJUSTING SCREW  
(Aim: page 3-14)

(1) SUSPENSION  
(Loose, wear, damage)

(7) AIR CLEANER  
(Contamination, clogging, replacement: page 3-6)

(8) SYNCHRONIZATION ADJUSTING SCREW  
(Synchronization: page 3-9)

(9) BRAKE HOSE  
(Leakage, degradation,  
damage)

(10) BRAKE CALIPER  
(Pad wear)  
• Left saddle bag

(19) TIMING HOLE COVER (Ignition timing)  
• Lower fairing

(18) TIMING BELT (Cracks, damage,  
contamination: page 3-12)

(17) RADIATOR HOSE  
(Leakage, degradation, damage)

(16) OIL DRAIN BOLT  
(Oil replacement: page 3-8)

(15) VALVE CLEARANCE (page 3-6)

(14) OIL FILTER  
(Replacement: page 3-8)

(11) TIRE (Wear,  
damage, pressure)

(12) WHEEL (Damage,  
runout, corrosion)

(13) SIDE STAND (Operation)

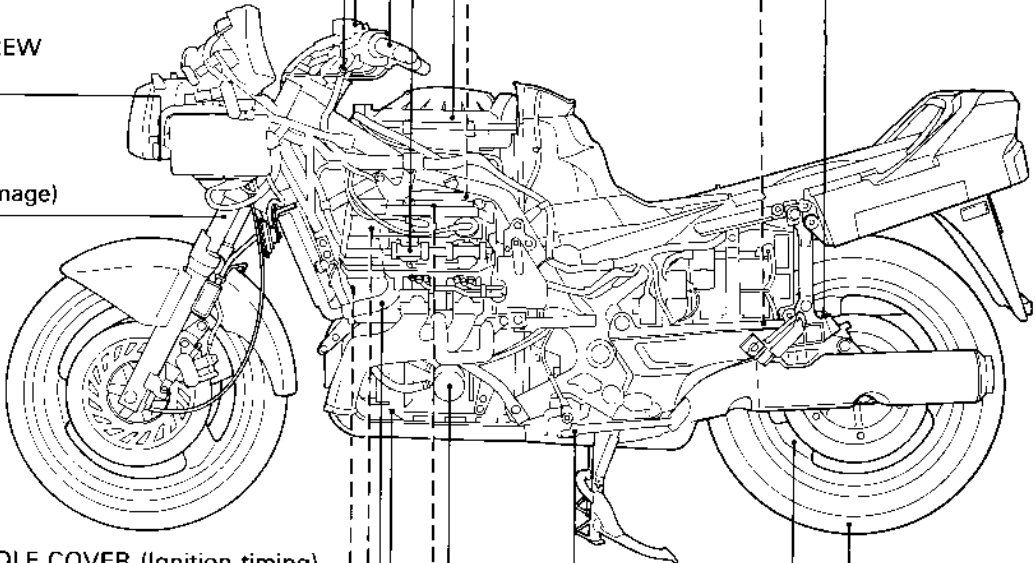

# Maintenance Schedule

'91-'94

Perform the PRE-RIDE INSPECTION in the Owner's Manual at each scheduled maintenance period.

I: Inspect and clean, adjust, lubricate, or replace if necessary.

R: Replace C: Clean L: Lubricate A: Adjust

The following items require some mechanical knowledge. Certain items (particularly those marked \* and \*\*) may require more technical information and tools. Consult an authorized Honda dealer.

Item	Frequency	Whichever comes first Note	Odometer Reading (Note 1)								Refer to page		
			x 1,000 mi	0.6	4	8	12	16	20	24			
			x 100 km	10	64	128	192	256	320	384			
Months		6	12	18	24	30	36						
Emission Related Items	* Fuel Line				I			I					Note 5
	* Throttle Operation					I		I					Note 5
	* Carburetor Choke					I		I					Note 5
	Air Cleaner		Note 2					R				R	3-6
	Spark Plugs				I	R	I	R	I	R			3-6
	* Valve Clearance				I				I				3-6
	Engine Oil				R		R		R		R		3-8
	Engine Oil Filter				R		R		R		R		3-8
	* Carburetor Synchronization				I		I		I		I		3-9
	* Engine Idle Speed				I	I	I	I	I	I	I		3-11
	Radiator Coolant		Note 3				I		I		R		3-11
	* Cooling System						I		I		I		Note 5
	* Secondary Air Supply System		Note 6				I		I		I		Note 5
	* Evaporative Emission Control System		Note 4					I			I		Note 5
* Timing Belt						I Every 60,000 mi (96,000 km) R Every 90,000 mi (144,000 km)					3-12		
Non-emission Related Items	Final Drive Oil					I		I				R	Note 5
	Brake Fluid		Note 3			I	I	R	I	I	R		Note 5,3-12
	Brake Pads Wear					I	I	I	I	I	I		Note 5
	Brake System				I		I		I		I		Note 5,3-13
	* Brake Light Switch						I		I		I		Note 5
	* Headlight Aim						I		I		I		3-14
	Clutch System						I		I		I		Note 5
	Clutch Fluid		Note 3			I	I	R	I	I	R		Note 5
	Side Stand						I		I		I		Note 5
	* Suspension						I		I		I		Note 5
	* Nuts, Bolts, Fasteners				I		I		I		I		Note 5
	** Wheels/Tires						I		I		I		Note 5
** Steering Head Bearings				I		I		I		I		Note 5	

\* Should be serviced by your authorized Honda dealer, unless the owner has proper tools and service data and is mechanically qualified.

\*\* In the interest of safety, we recommend these items be serviced only by your authorized Honda dealer.

- Notes:
- At higher odometer readings, repeat at the frequency interval established here.
  - Service more frequently when riding in unusually wet or dusty areas.
  - Replace every 2 years, or at indicated odometer interval, whichever comes first. Replacement requires mechanical skill.
  - '91-'93: Standard California type and U.S.A. ABS/TCS type.  
'94: California type.
  - Refer to Common Service Manual.
  - All U.S.A. types.

## After '94

Perform the PRE-RIDE INSPECTION in the Owner's Manual at each scheduled maintenance period.

I: Inspect and clean, adjust, lubricate, or replace if necessary.

R: Replace C: Clean L: Lubricate A: Adjust

The following items require some mechanical knowledge. Certain items (particularly those marked \* and \*\*) may require more technical information and tools. Consult an authorized Honda dealer.

Item	Frequency	Whichever comes first Note	Odometer Reading (Note 1)						Refer to page		
			x 1,000 mi	0.6	4	8	12	16		20	24
			x 100 km	10	64	128	192	256		320	384
			Months	6	12	18	24	30	36		
* Fuel Line					I			I			Note 5
* Throttle Operation					I			I			Note 5
* Carburetor Choke					I			I			Note 5
Air Cleaner		Note 2					R			R	3-6
Spark Plugs				I	R	I	R	I	R		3-6
* Valve Clearance								I			3-6
Engine Oil			R		R		R		R		3-8
Engine Oil Filter			R		R		R		R		3-8
* Carburetor Synchronization			I		I		I		I		3-9
* Engine Idle Speed			I	I	I	I	I	I	I		3-11
Radiator Coolant		Note 3			I		I		R		3-11
* Cooling System					I		I		I		Note 5
* Secondary Air Supply System		Note 6			I		I		I		Note 5
* Evaporative Emission Control System		Note 4					I		I		Note 5
* Timing Belt					I Every 60,000 mi (96,000 km) R Every 90,000 mi (144,000 km)						3-12
Final Drive Oil					I		I		R		Note 5
Brake Fluid		Note 3			I	I	R	I	I	R	Note 5,3-12
Brake Pads Wear					I	I	I	I	I		Note 5
Brake System			I		I		I		I		Note 5,3-13
* Brake Light Switch					I		I		I		Note 5
* Headlight Aim					I		I		I		3-14
Clutch System					I		I		I		Note 5
Clutch Fluid		Note 3			I	I	R	I	I	R	Note 5
Side Stand					I		I		I		Note 5
* Suspension					I		I		I		Note 5
* Nuts, Bolts, Fasteners			I		I		I		I		Note 5
** Wheels/Tires					I		I		I		Note 5
** Steering Head Bearings			I		I		I		I		Note 5

\* Should be serviced by your authorized Honda dealer, unless the owner has proper tools and service data and is mechanically qualified.

\*\* In the interest of safety, we recommend these items be serviced only by your authorized Honda dealer.

Notes: 1. At higher odometer readings, repeat at the frequency interval established here.

2. Service more frequently when riding in unusually wet or dusty areas.

3. Replace every 2 years, or at indicated odometer interval, whichever comes first. Replacement requires mechanical skill.

4. California type.

5. Refer to Common Service Manual.

6. All U.S.A. types.

## Air Cleaner

Remove the top shelter (page 2-5).

Remove the eight screws and the air cleaner housing cover.

Remove the air cleaner and discard it.

Install a new air cleaner and the removed parts in the reverse order of removal.

**Torque: Housing cover screw:**

**0.9 N·m (0.09 kg-m, 0.65 ft-lb)**

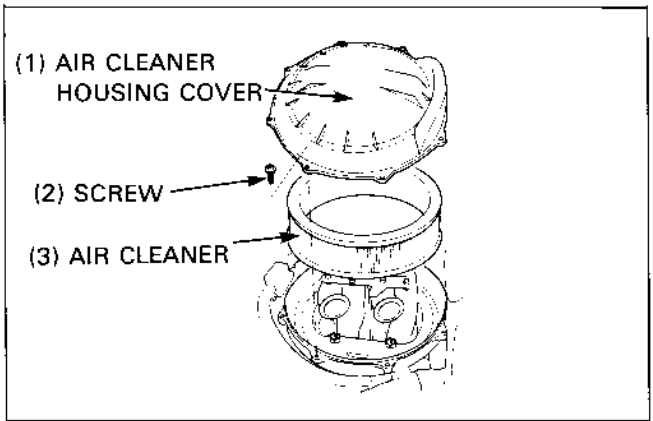

## Spark Plugs

Remove the maintenance cover (page 2-5).

Disconnect the spark plug caps and clean any dirt from around the spark plug bases.

Remove the spark plugs.

Visually inspect the spark plug electrodes for wear. The center electrode should have square edges and the side electrode should have a constant thickness. Discard the spark plug if there is apparent wear or if the insulator is cracked or chipped.

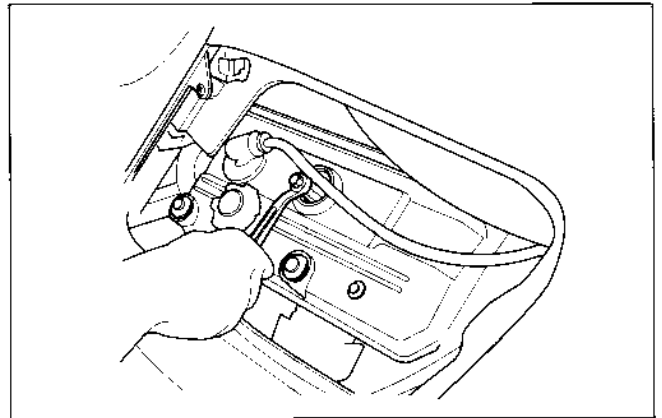

For recommended spark plug, see page 1-15.

Measure the spark plug gaps using a wire-type feeler gauge.

**Spark plug gap: 0.8—0.9 mm (0.031—0.035 in)**

If necessary, adjust the gap by carefully bending the side electrode.

Install the spark plugs.

**Torque: 11 N·m (1.1 kg-m, 8 ft-lb)**

Connect the spark plug caps and install the maintenance cover (page 2-5).

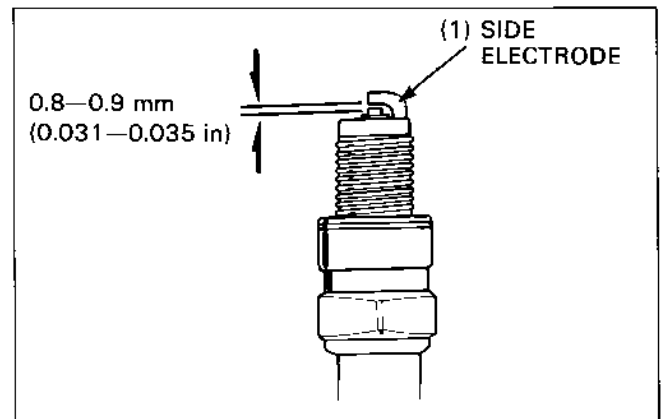

## Valve Clearance

### Inspection

#### NOTE

- Inspect and adjust valve clearance while the engine is cold (below 35°C/95°F)

Remove the cylinder head covers (page 8-2).

Remove the timing hole cover.

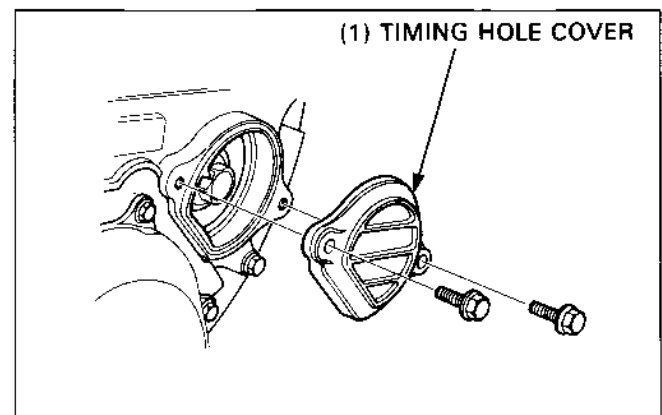

Turn the crankshaft clockwise and align the T1 mark on the timing belt drive pulley guide plate with the timing belt cover Index mark.

Make sure the No. 1 piston is at Top Dead Center (TDC) on the compression stroke and the RIGHT camshaft index lines align with the top of the cylinder head and face OUT as shown.

If the No. 1 piston is not at TDC on the compression stroke, turn the crankshaft clockwise one full turn and realign the T1 mark with the index mark.

Measure the No. 1 cylinder valve clearances for the intake and exhaust valves by inserting a feeler gauge between the cam lobes and the valve lifters.

#### Valve clearance:

**IN:** 0.13–0.19 mm (0.005–0.007 in)

**EX:** 0.22–0.28 mm (0.009–0.11 in)

Record the clearance for each valve for reference, if shim selection is needed.

Turn the crankshaft clockwise 1/4 turn to align the T4 mark with the index mark. The LEFT camshaft index lines should align with the top of the cylinder head and face IN.

Measure and record the No. 4 cylinder valve clearances.

Turn the crankshaft clockwise 3/4 turn to align the T1 mark. The RIGHT camshaft index lines should align with the top of the cylinder head and face IN.

Measure and record the No. 3 cylinder valve clearances.

Turn the crankshaft clockwise 1/4 turn to align the T4 mark. The LEFT camshaft index lines should align with the top of the cylinder head and face OUT.

Measure and record the No. 2 cylinder valve clearances.

### Shim Selection

If the valve clearance is not correct:

Remove the camshaft (page 8-4), valve lifter and shim (page 8-8).

#### NOTE

- Be careful not to allow the shims to fall into the crankcase. The shim may occasionally stick to the valve lifter.
- Mark the positions of all valve lifters and shims to ensure correct reassembly.
- Remove the shim with tweezers or a magnet.

Clean the valve lifter with compressed air.

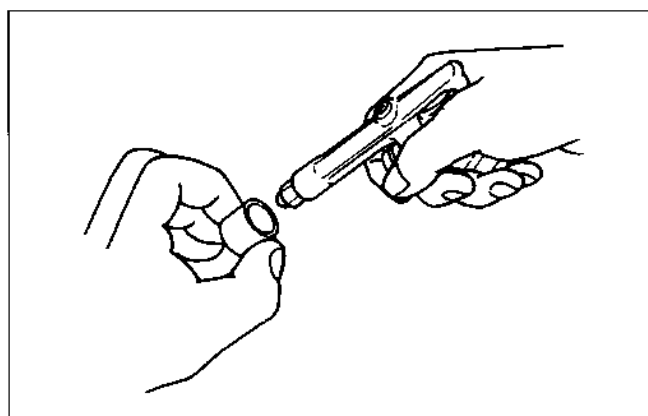
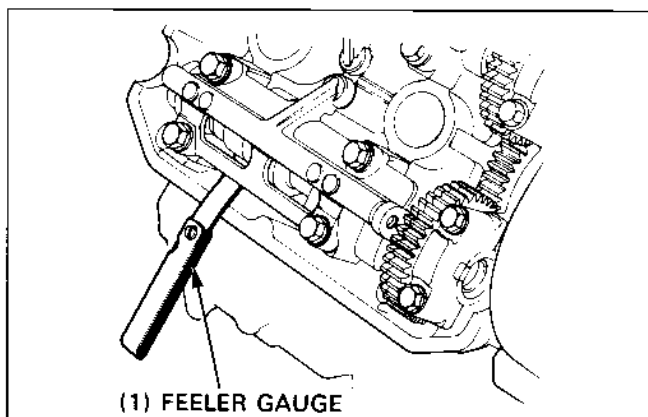
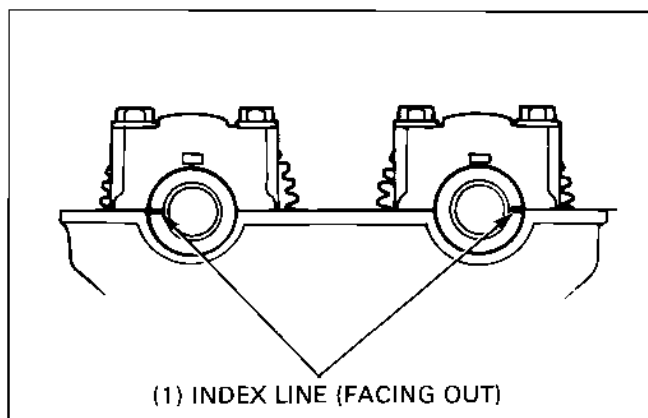
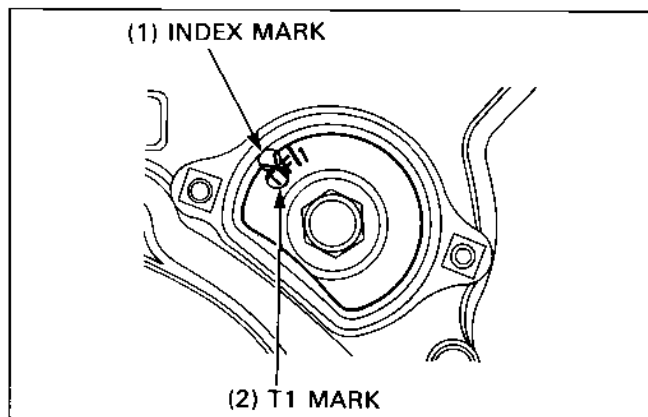

## Maintenance

Clean the shim with a clean shop towel.  
Measure the shim thickness with a micrometer and record it.

### NOTE

- Sixty-five different shims are available in thickness intervals of 0.025 mm. The thinnest is 1.200 mm and the thickest is 2.800 mm.

To select the shim needed to bring the valve clearance within the specification, use the following formula:

$$a = b - c + d$$

- a: new shim thickness  
b: recorded valve clearance  
c: specified valve clearance  
d: old shim thickness

### Example

b: recorded valve clearance = 0.18 mm

c: specified valve clearance = 0.16 mm

d: old shim thickness = 1.850 mm

$$a = 0.18 - 0.16 + 1.850$$

$$a = 1.870$$

New shim thickness = 1.875 mm

### NOTE

- If the required thickness of the new shim is more than 2.800 mm, the valve seat is probably heavily carboned. Reface the seat, recheck valve clearance and reselect the shim.

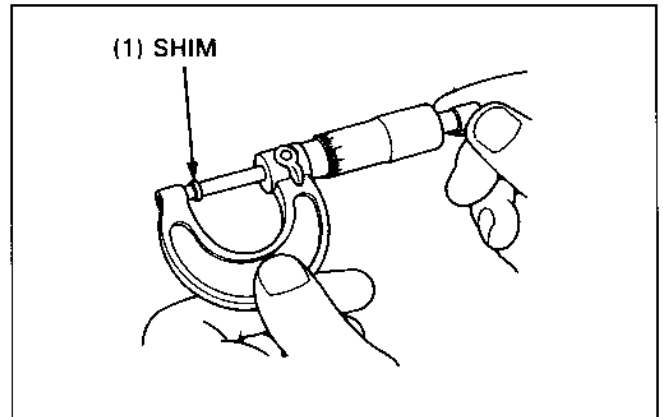

## Engine Oil

### Engine Oil and Filter Change

#### CAUTION

- Used engine oil may cause skin cancer if repeatedly left in contact with the skin for prolonged periods. Although this is unlikely unless you handle used oil on a daily basis, it is still advisable to thoroughly wash your hands with soap and water as soon as possible after handling used oil.

#### NOTE

- Change the engine oil with the engine warm and the motorcycle on its center stand to assure complete and rapid draining.

Remove the lower fairing (page 2-4).

Remove the oil filler cap and oil drain bolt, and drain the engine oil.

Remove the oil filter with the special tool and let the remaining oil drain out. Discard the oil filter.

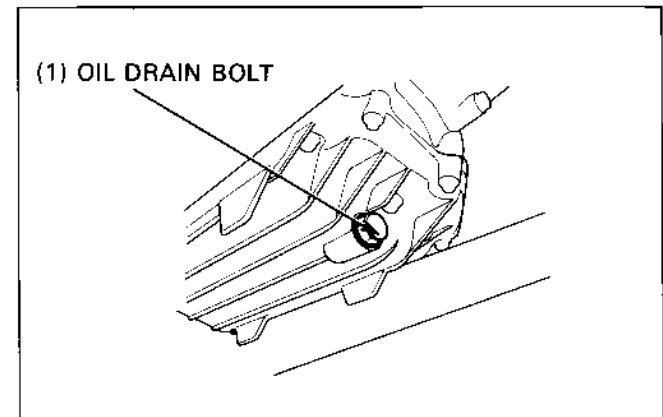

'91-'95 shown:

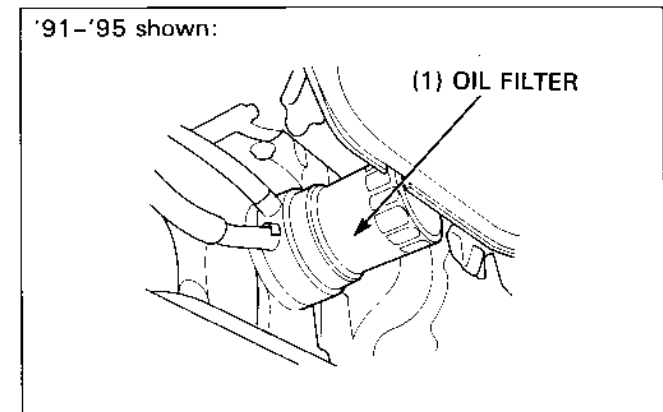

 S TOOL

Oil filter wrench

07HAA-PJ70100



Apply a thin coat of engine oil to the O-ring on the new oil filter.

Install the oil filter and tighten it with an oil filter wrench.

**Torque: 10 N·m (1.0 kg-m, 7 ft-lb)**

Check that the sealing washer on the drain bolt is in good condition. Install the drain bolt and tighten it.

**Torque: 38 N·m (3.8 kg-m, 27 ft-lb)**

Fill the crankcase with the recommended engine oil (page 1-7).

Install the oil filler cap.

Start the engine and let it idle for a few minutes.

Stop the engine. After a few minutes, check the oil level inspection window.

The oil level should be between the upper and lower level marks.

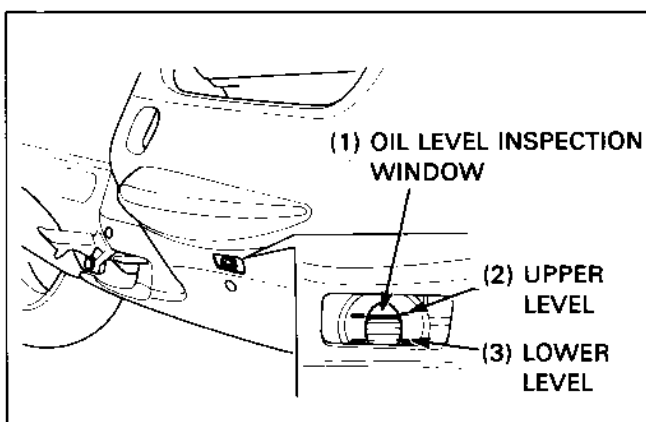
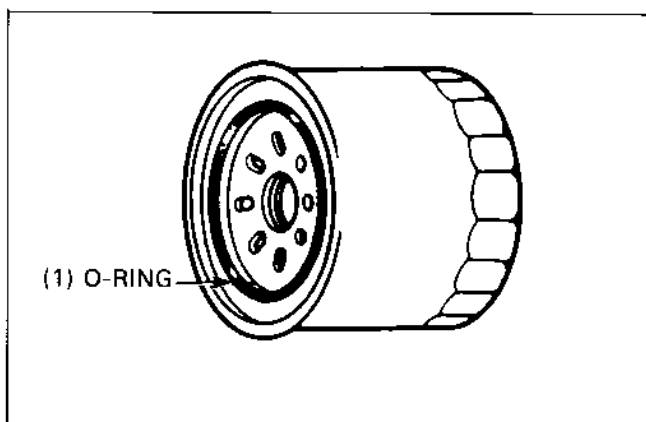

If required, remove the filler cap, and add the specified oil up to the upper level mark. Do not overfill.

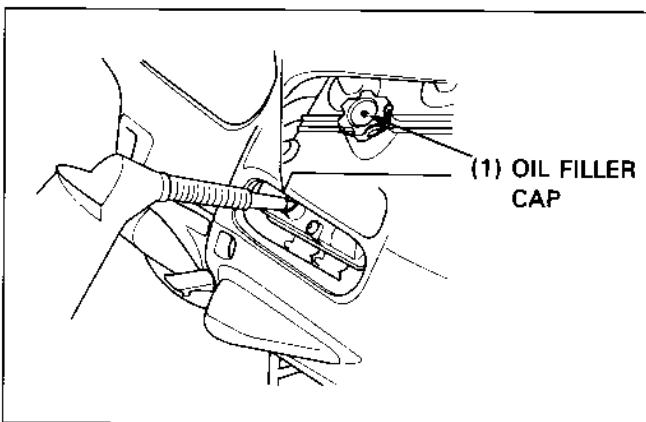

## Carburetor Synchronization

### NOTE

- Refer to section 2 of Common Service Manual for carburetor synchronization procedure.
- Synchronize the carburetor with the engine at normal operating temperature, the transmission in neutral and the motorcycle supported upright.

Remove the left and right fairing pockets (page 2-6).

Disconnect the No. 3 cylinder vacuum tube from the auto fuel valve, apply vacuum to the auto fuel valve and pinch the tube with a clamp.

Connect the vacuum gauge adaptor to the No. 3 cylinder vacuum tube.

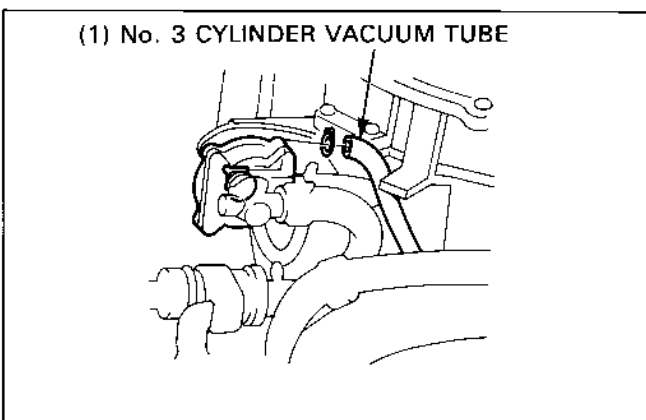

## Maintenance

(All U.S.A. types)

Disconnect the No. 2 and 4 cylinder vacuum tubes at the 3-way joint, and connect the vacuum gauge adaptors.

(Canada type)

Remove the vacuum tube caps from the No. 2 and 4 cylinder vacuum tubes and install the vacuum gauge adaptor tubes.

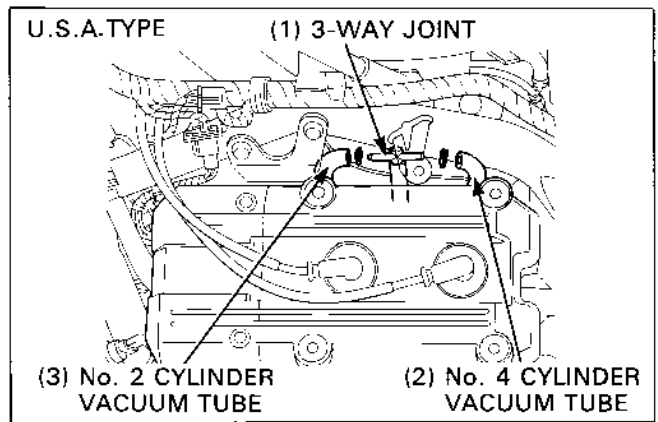

'91-'93:

(Standard California type and U.S.A. ABS/TCS type)

After '93:

(California type)

Disconnect the No. 1 cylinder vacuum tube from the EVAP CAV control valve apply vacuum to the EVAP CAV control valve and pinch the tube with a clamp.

Connect the vacuum gauge adaptor to the No. 1 cylinder vacuum tube.

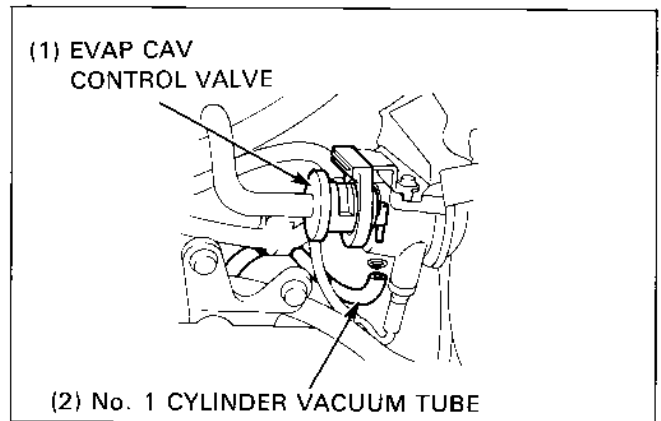

'91-'93:

(Standard 49 state and Canada type)

After '93:

(49 state and Canada type)

Remove the vacuum joint tube cap from the No. 1 cylinder vacuum tube and install the vacuum gauge adaptor tube.

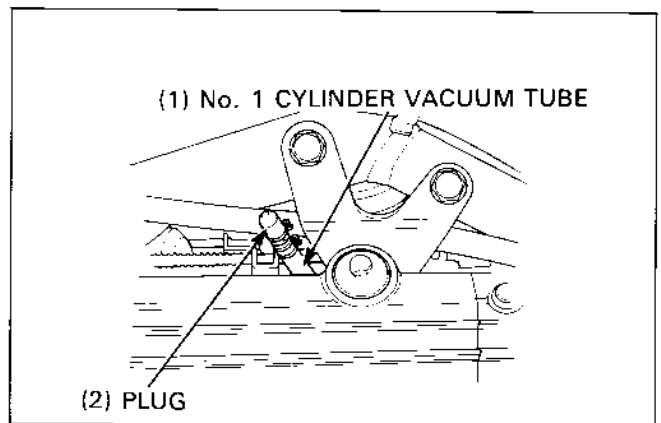

### NOTE

- The base carburetor is the No. 4 carburetor.

Adjust the carburetor synchronization by turning the synchronization adjusting screw.

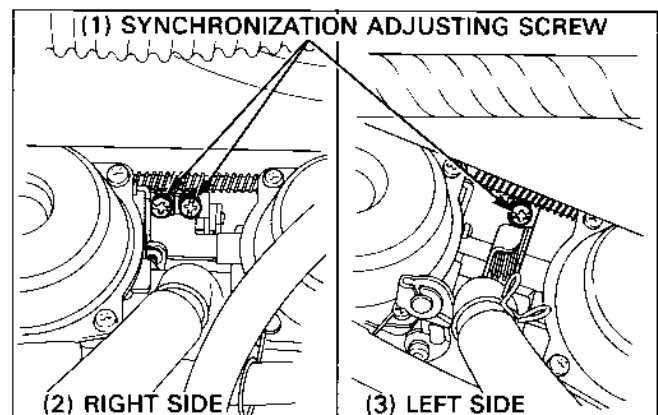

## Engine Idle Speed

### NOTE

- Inspect and adjust idle speed after all other engine adjustments are within specifications.
- Engine must be warm for accurate adjustment. Ten minutes of stop-and-go riding is sufficient.

Warm up the engine, shift the transmission into neutral and place the motorcycle on its center stand. Open the top shelter lid with the ignition key. Adjust the idle speed by turning the throttle stop control knob.

Idle speed:  $1,200 \pm 100$  rpm

$1,000 \pm 100$  rpm (Canada type)

## Radiator Coolant

Check the coolant level in the reserve tank while the engine is at normal operating temperature. The level should be between the UPPER and LOWER level lines.

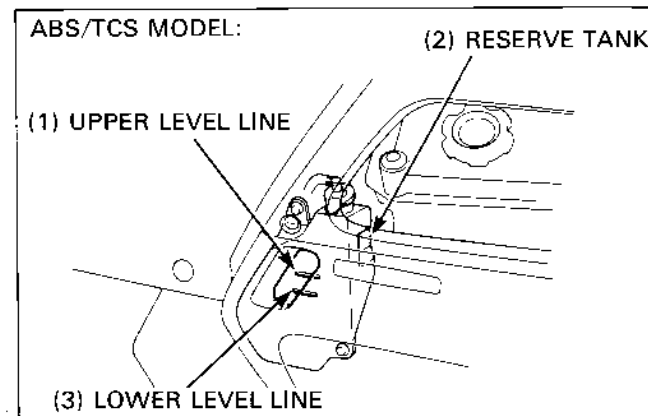
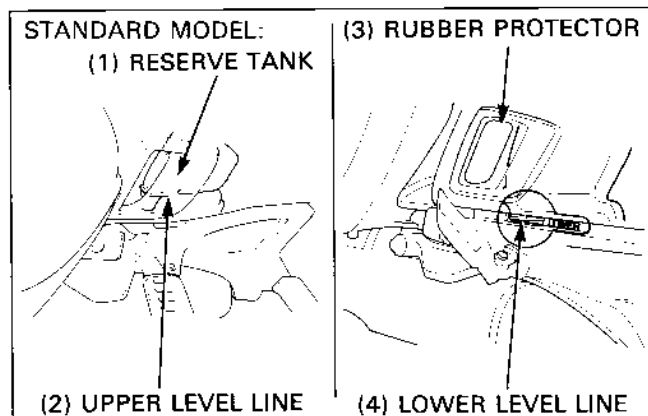
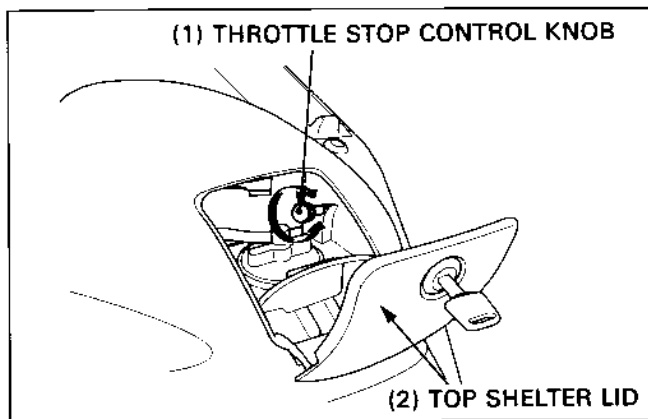

(Standard Model)

If the level is low, remove the right side cover (page 2-2), remove the filler cap and add the recommended coolant to the UPPER level line.

### NOTE

- Do not remove the rubber protector.

For coolant draining/refilling, see section 6.

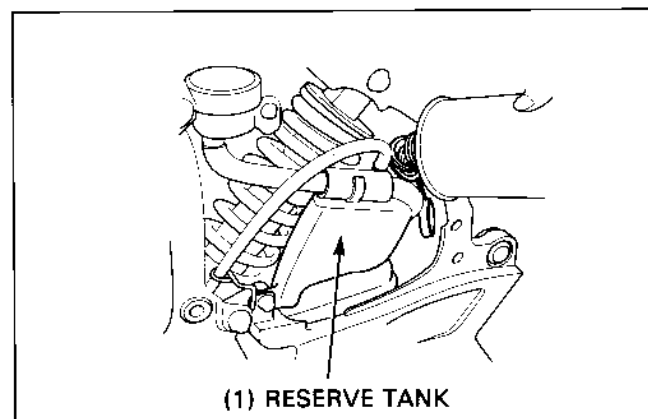

(ABS/TCS or LBS-ABS/TCS model)

If the level is low, remove the right maintenance cover (page 2-5), remove the filler cap and add the recommended coolant the UPPER level line.

For coolant draining/refilling, see section 6.

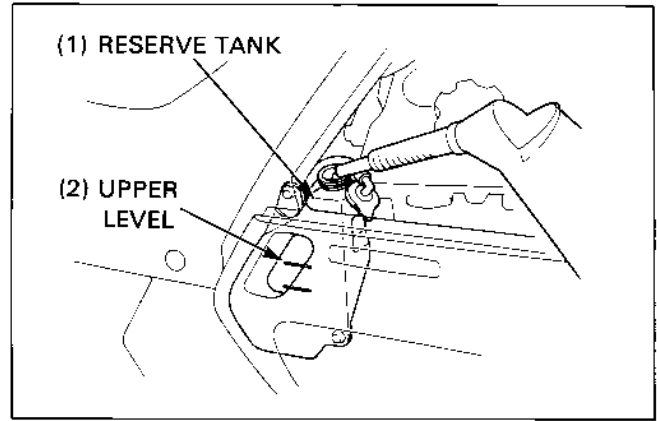

## Timing Belt

Remove the reduction holder covers (page 8-2).

Remove the timing hole cover (page 3-5).

Check the timing belt for cracking, damage or contamination with oil and/or coolant while turning the crankshaft clockwise.

If the belt is cracked or damaged, replace it with a new one (page 8-12).

If the belt is contaminated with oil and/or coolant, remove the timing belt cover (page 8-3). Clean the timing belt housing and pulleys thoroughly, then replace the belt with a new one.

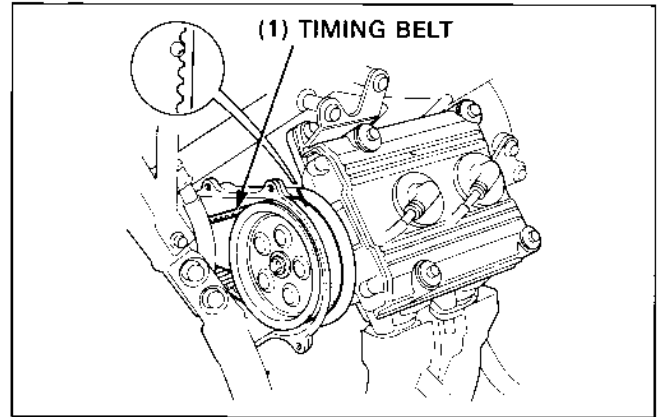

## Brake Fluid

### NOTE

- For front brake fluid level checking and fluid replacement, refer to the Common Service Manual. For fluid replacement on the LBS-ABS/TCS model, see page 15-2.

### Rear Brake Fluid Level

Remove the right saddlebag (page 2-2).

Check the fluid level by viewing from the rear as shown. The level should be between the UPPER and LOWER level lines.

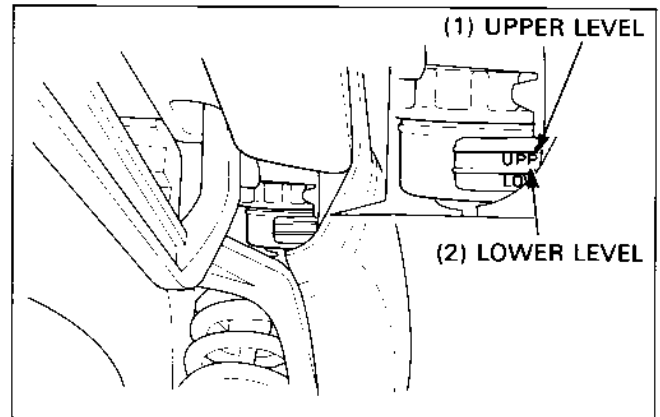

## Brake System (LBS-ABS/TCS model)

### NOTE

- The LBS-ABS/TCS brake pedal operation should be inspected as described below.
- The lever brake line of the LBS-ABS/TCS model should be inspected in the same manner as the lever brake line of the standard model and the ABS/TCS model.

Place the motorcycle on its center stand and shift the transmission into neutral.

Push the secondary master cylinder by pressing the left front caliper.

The rear wheel should not be able to rotate when the secondary master cylinder is pushed forward.

Also check the smooth operation of the brake linkage.

The rear wheel should not be able to rotate when the brake pedal is pressed.

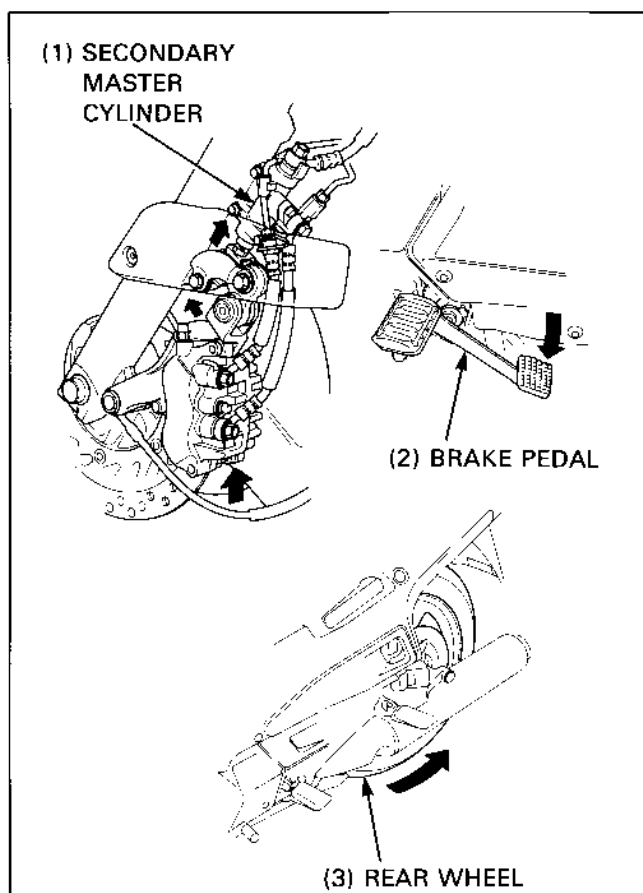

Raise the front wheel off the ground by supporting the engine.

The front wheel should not be able to rotate when the brake pedal is pressed.

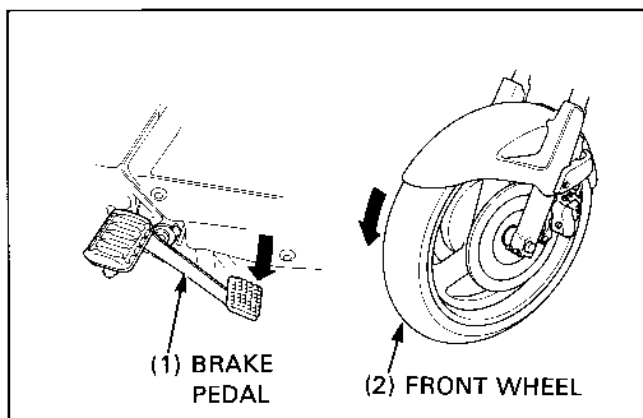

## Headlight Aim

**▲ WARNING**

- An improperly adjusted headlight may blind on-coming drivers, or it may fail to light the road for a safe distance.

Place the motorcycle on a level surface.

**Horizontal:**

Insert a screwdriver into the hole in the middle fairing inner cover, and turn the adjusting screw to adjust the headlight beam.





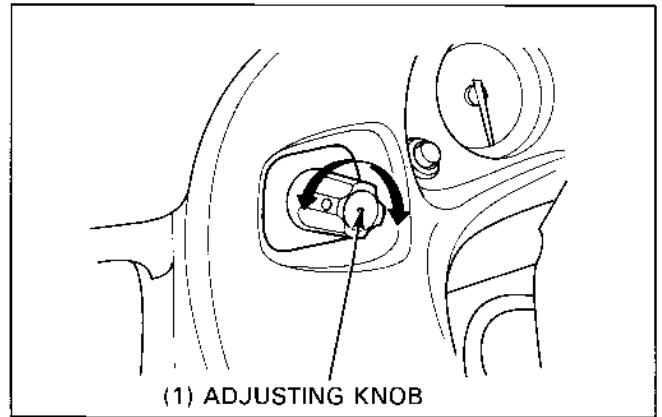
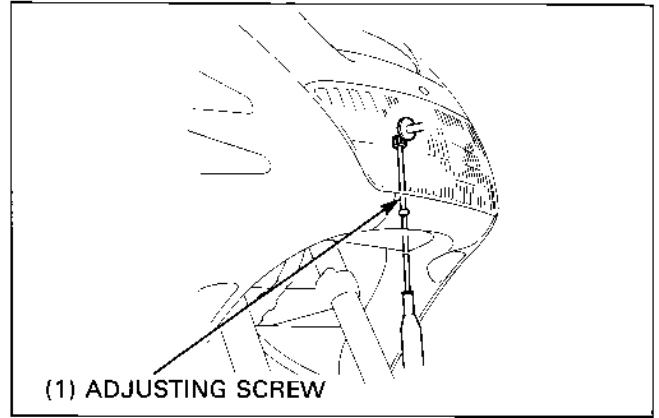









**Vertical:**

Adjust the headlight beam to suit riding conditions by turning the headlight adjusting knob.



# Symbols

The symbols used throughout this manual show specific service procedures. If supplementary information is required pertaining to these symbols, it would be explained specifically in the text without the use of the symbols.

	<p>Replace the part(s) with new one(s) before assembly.</p>
	<p>Use special tool</p>
	<p>Use optional tool. Use the same procedure you use to order parts.</p>
 <p>10 (1.0, 7.2)</p>	<p>Torque specification.    10 N·m (1.0 kg-m, 7.2 ft-lb)</p>
	<p>Use recommended engine oil, unless otherwise specified.</p>
	<p>Use molybdenum oil solution (mixture of the engine oil and molybdenum grease in a ratio of 1 : 1).</p>
	<p>Use multi-purpose grease (Lithium based multi-purpose grease NLGI #2 or equivalent)</p>
	<p>Use molybdenum disulfide grease (containing more than 3% molybdenum disulfide, NLGI #2 or equivalent)          Example: Molykote® BR-2 plus manufactured by Dow Corning, U.S.A.          Multi-purpose M-2 manufactured by Mitsubishi Oil Japan</p>
	<p>Use molybdenum disulfide paste (containing more than 40% molybdenum disulfide, NLGI #2 or equivalent)          Example: Molykote® G-n Paste manufactured by Dow Corning, U.S.A.          Honda Moly 60 (U.S.A. only)          Rocol ASP manufactured by Rocol Limited, U.K.          Rocol Paste manufactured by Sumico Lubricant, Japan</p>
	<p>Use silicone grease</p>
	<p>Apply a locking agent. Use a middle strength locking agent unless otherwise specified.</p>
	<p>Apply sealant</p>
	<p>Use brake fluid, DOT 3 or DOT 4. Use the recommended brake fluid, unless otherwise specified.</p>
	<p>Use Fork or Suspension Fluid.</p>